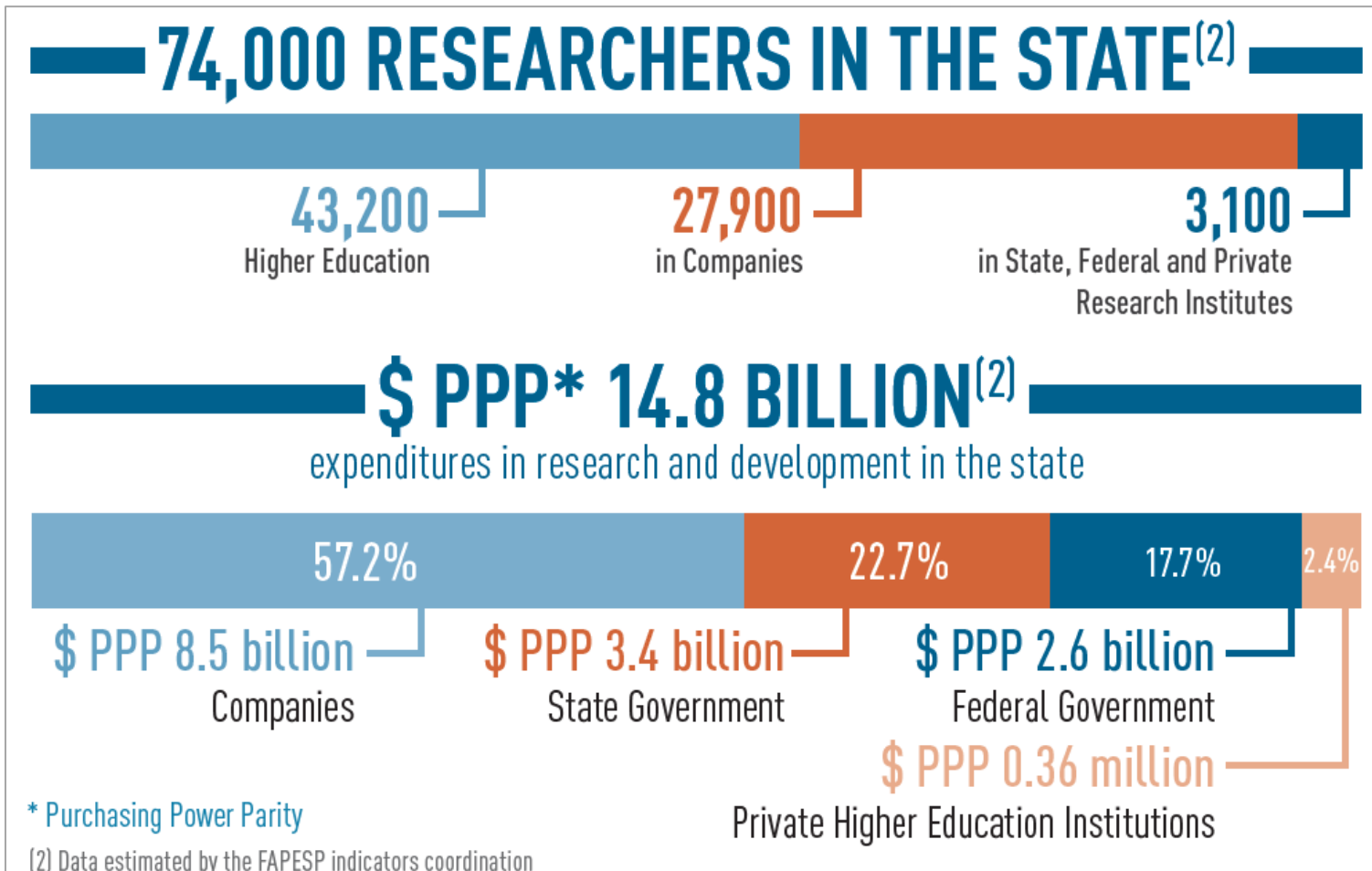

Ciência e Tecnologia em São Paulo, Brasil

Carlos Henrique de Brito Cruz

Science Director

São Paulo Research Foundation, FAPESP

The S&T system in the state of São Paulo, Brazil



São Paulo: R&D Expenditures, 2012, by source

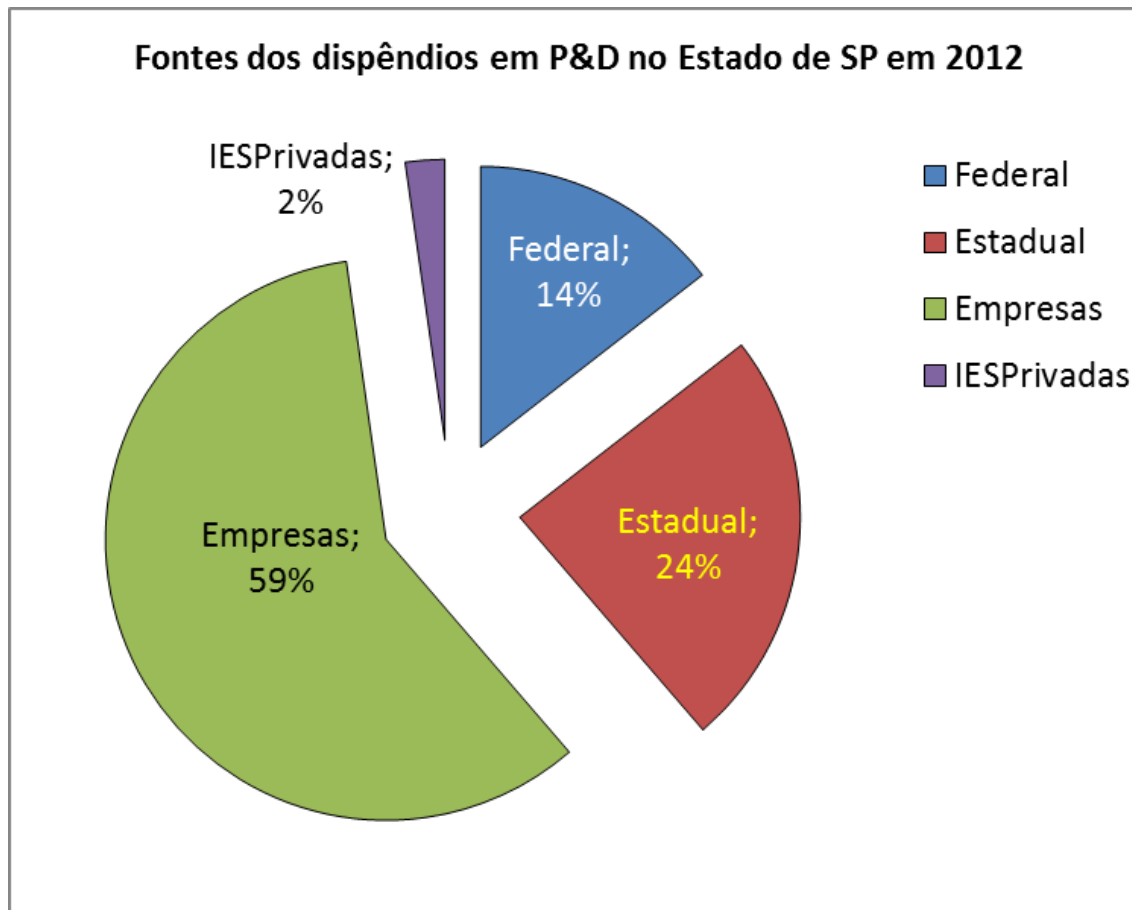

- R&D intensity – 1.7% of state GDP
 - From 1.52% em 2008
- Gov. expenditure
 - State 63%
 - Federal 37%

Brasil: R&D Expenditures, 2012, by source

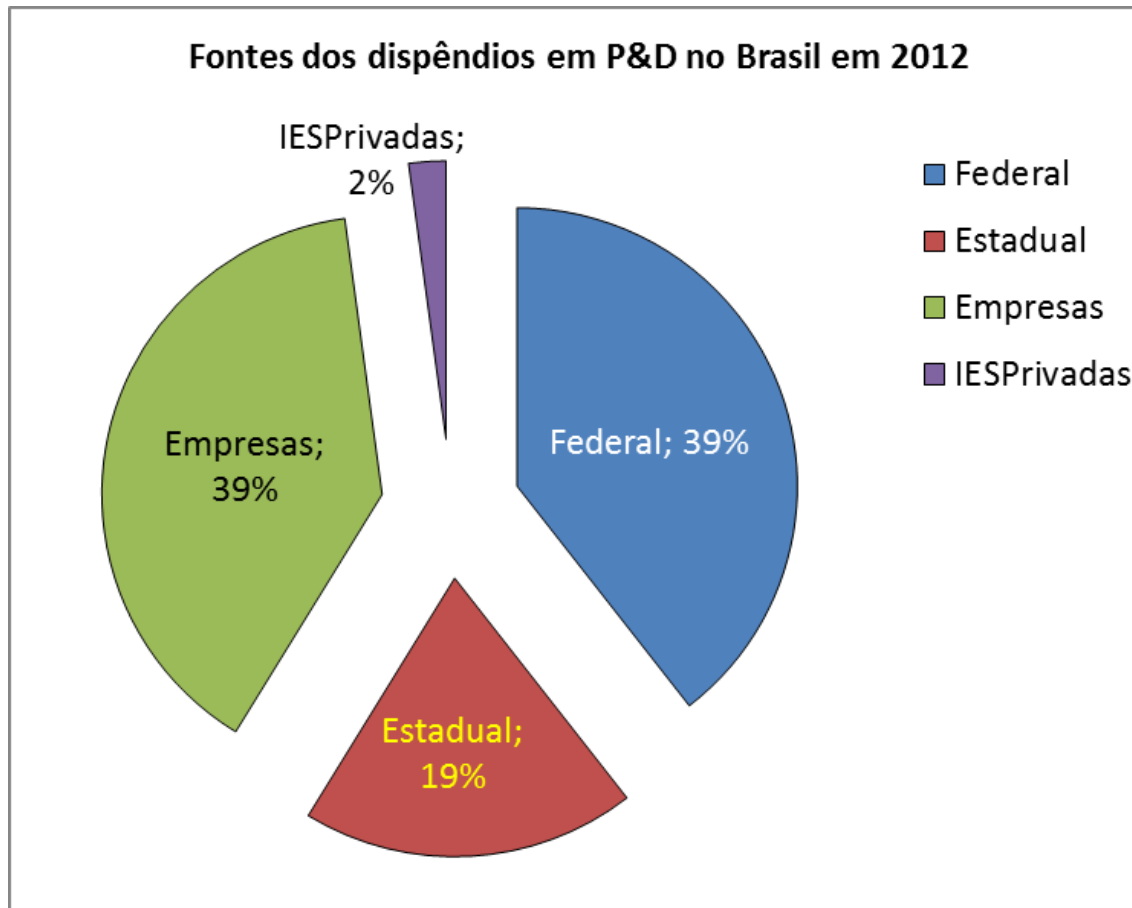

- R&D intensity – 1,15% of GDP
- Gov. expenditure
 - States 33%
 - Federal 67%

Brasil, outside São Paulo: R&D expenditures, 2012, by source

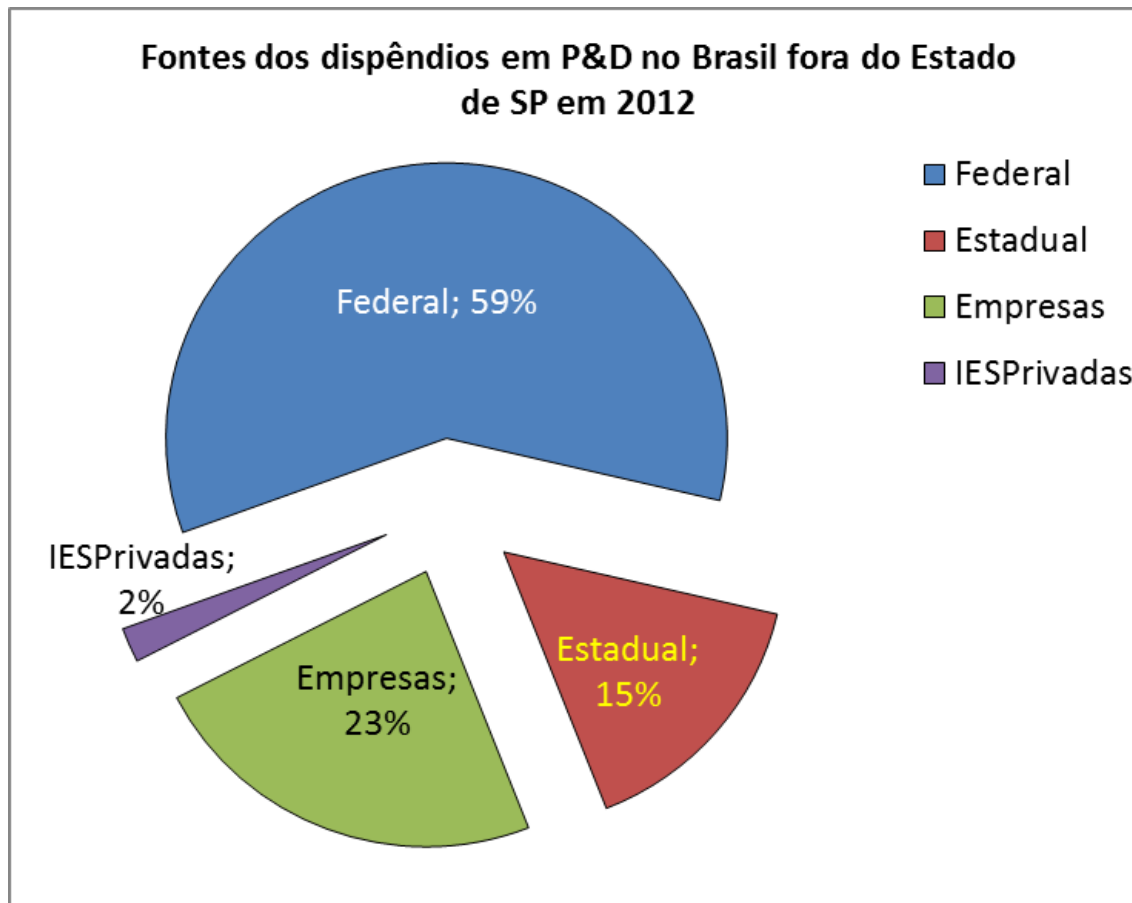

- R&D intensity – 0.95% of GDP
- Gov. expenditure
 - States 19%
 - Federal 81%

Brazil: State R&D expenditures, 2013

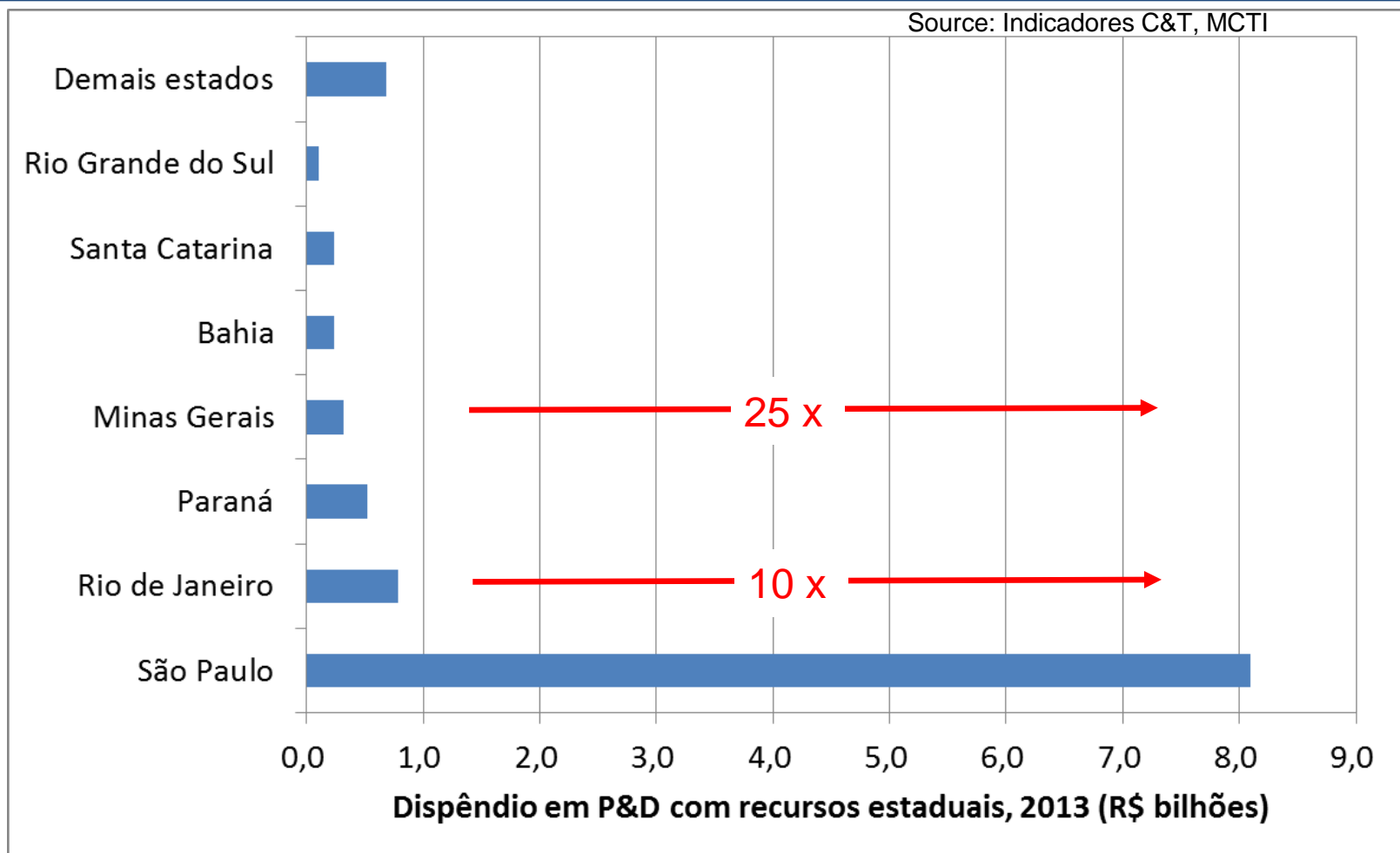

São Paulo R&D Expenditures

International comparison

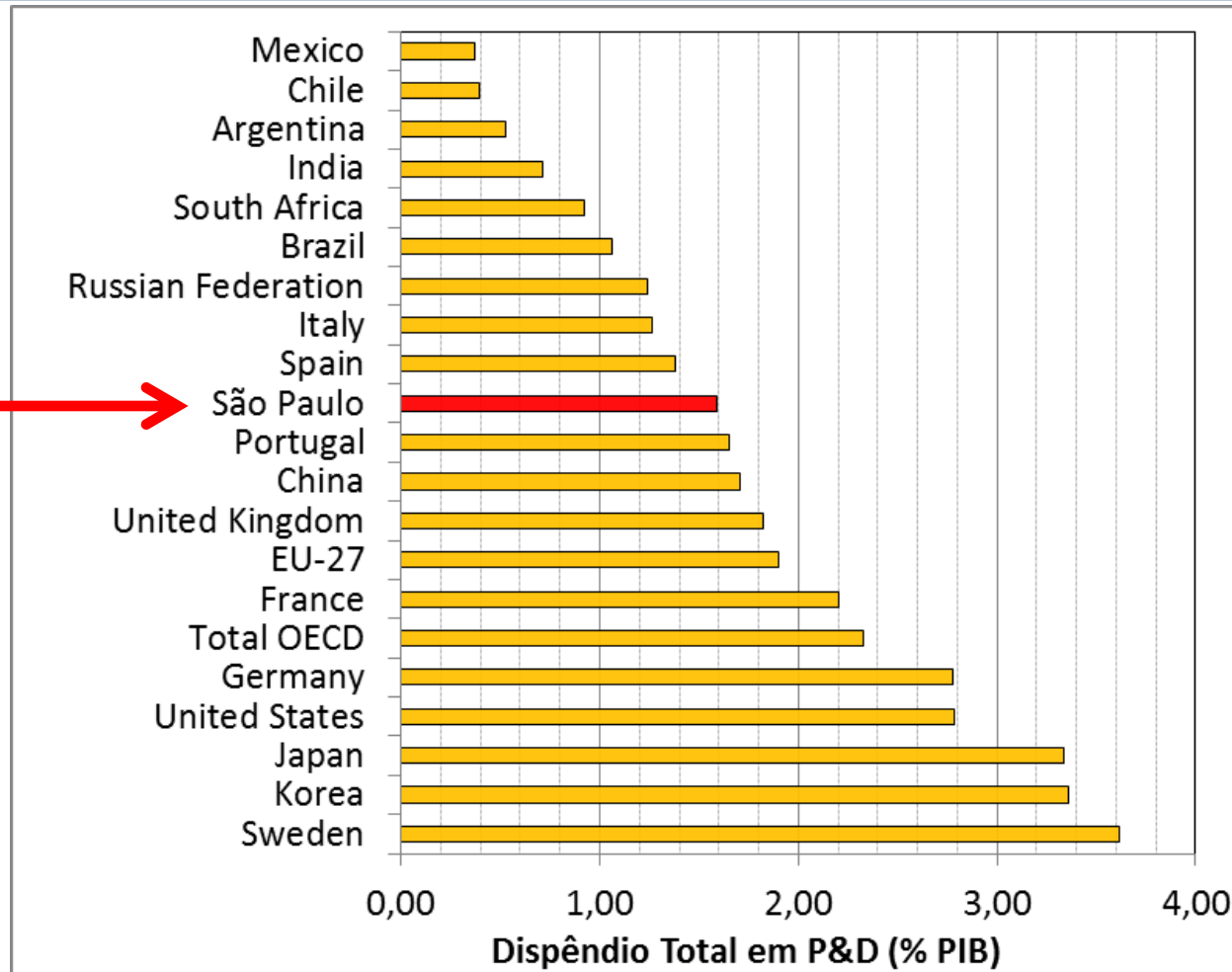

Fapesp: São Paulo Research Foundation

- Mission: support research in all fields
- Funded by the State of São Paulo with 1% of all state revenues
- All proposals are peer reviewed (25,000 proposals in 2015)
 - Average time for decision– 64 days; 40% success rate
- Annual budget: \$PPP 650 million in 2016
 - Fellowships
 - In Brazil: 2,000 SI, 1,100 MSc, 3,000 DrSc, 2,000 Post-docs, 800 other
 - Abroad: 1,200 per year
 - Academic R&D
 - RIDC/11 years, Thematic/5 years, Young Investigators/4 years, Regular/2 years
 - University-Industry Joint R&D: Microsoft, Agilent, Braskem, Oxiteno, SABESP, VALE, Natura, Petrobrás, Embraer, Padtec, Biolab, Cristalia, Whirlpool, Boeing, Astra-Zeneca, Intel
 - Engineering Res. Centers: 10 years joint grants FAPESP/Industry – PCBA, GSK, Natura, BG
 - Small bussiness R&D (PIPE): 1,500 SBE's (three awards per week in 2015)

São Paulo creates more articles than any country in Latin America

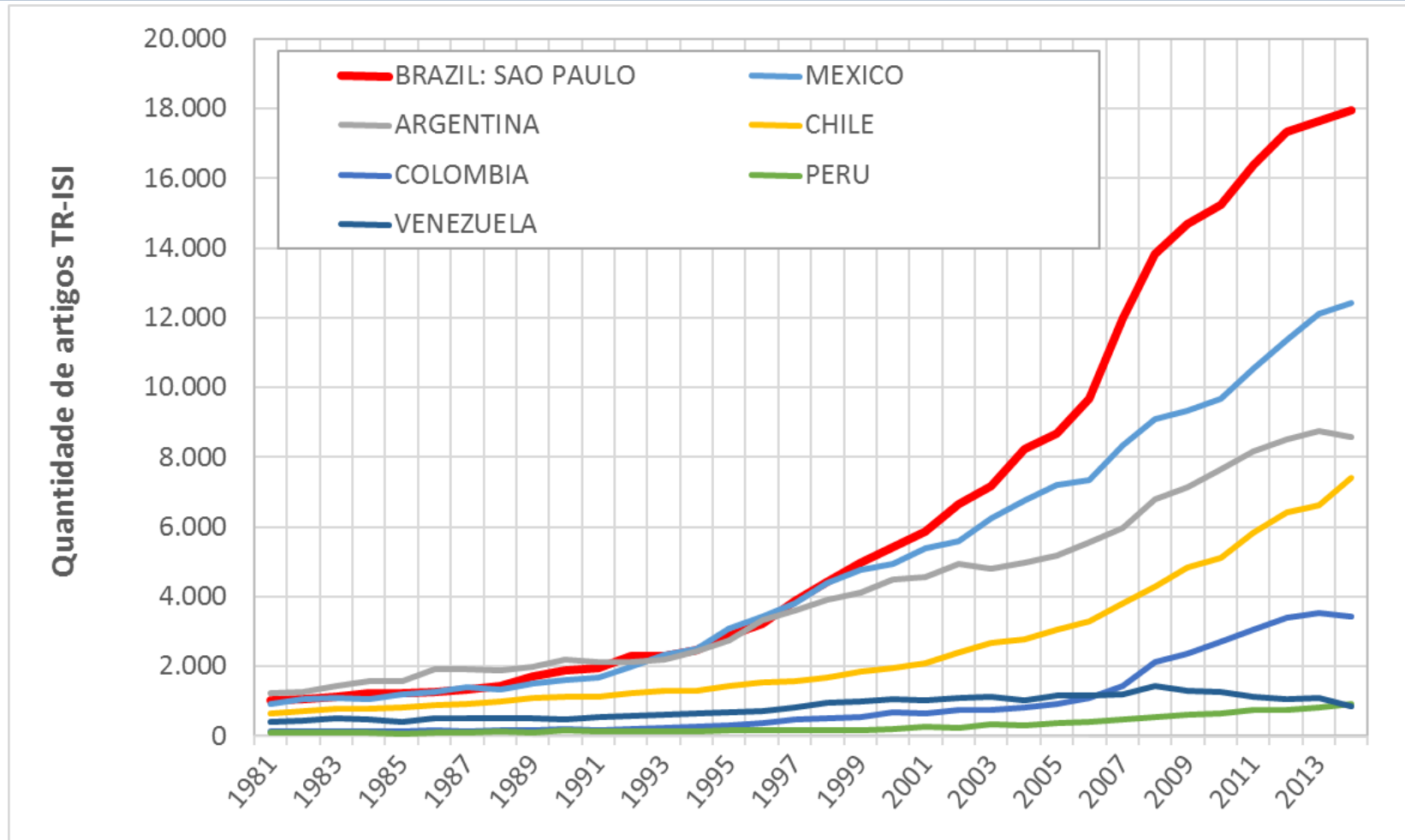

SOAR: Southern Observatory for Astrophysical Research

J.B. Haislip et al. "A..."
Nature 440, 1

50904",

Starting 2014:



Large Latin American Millimeter Array



GIANT MAGELLAN
TELESCOPE

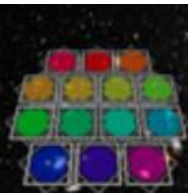

Javalambre
Physics of the Accelerating Universe
Astrophysical
Survey



Infrared afterglow
unveils the explosion
billion years ago.
These results demon-
used to trace the s
and reionization hi
Universe.

USP, UFRGS, UNC Ch.Hill
Fapesp, CNPq, NSF,...

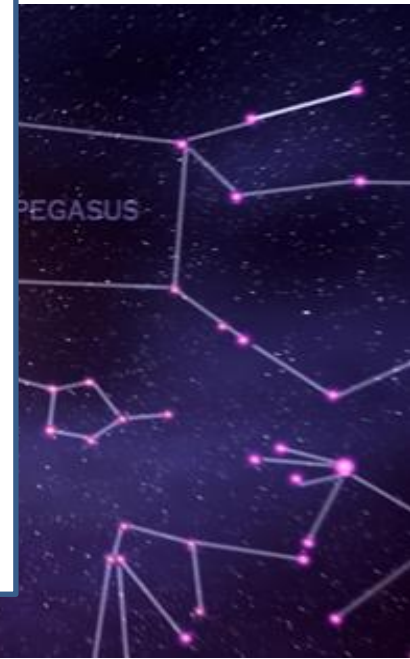

Unicamp 454 start-ups; 22 thousand jobs, R\$ 3 bilhões in revenues (2016)



BIOEN – FAPESP's Bioenergy research: 84 → 148 → 212 → 381 ton/Ha??

Review article

Sugarcane for bioenergy production: an assessment of yield and regulation of sucrose content

Alessandro J. Waclawovsky^{1,†,‡}, Paloma M. Sato^{1,‡}, Carolina G. Lembke¹, Paul H. Moore² and Glaucia M. Souza^{1,*}

¹Departamento de Bioquímica, Instituto de Química, Av. Prof. Lineu Prestes, São Paulo, Brazil

²Hawaii Agriculture Research Center, Kuniā, HI, USA

Table 1 Average, maximum and theoretical sugarcane yields (Australia, Colombia, and South Africa) and total dry matter production

Type of yield	Cane yield	Biomass*	
	t/(ha yr)	t/(ha yr)	g/(m ² d)
Commercial Average	84	39	10.7
Commercial maximum	148	69	18.8
Experimental maximum	212	98	27.0
Theoretical maximum	381	177	48.5

Brazil Energy Supply - 2014

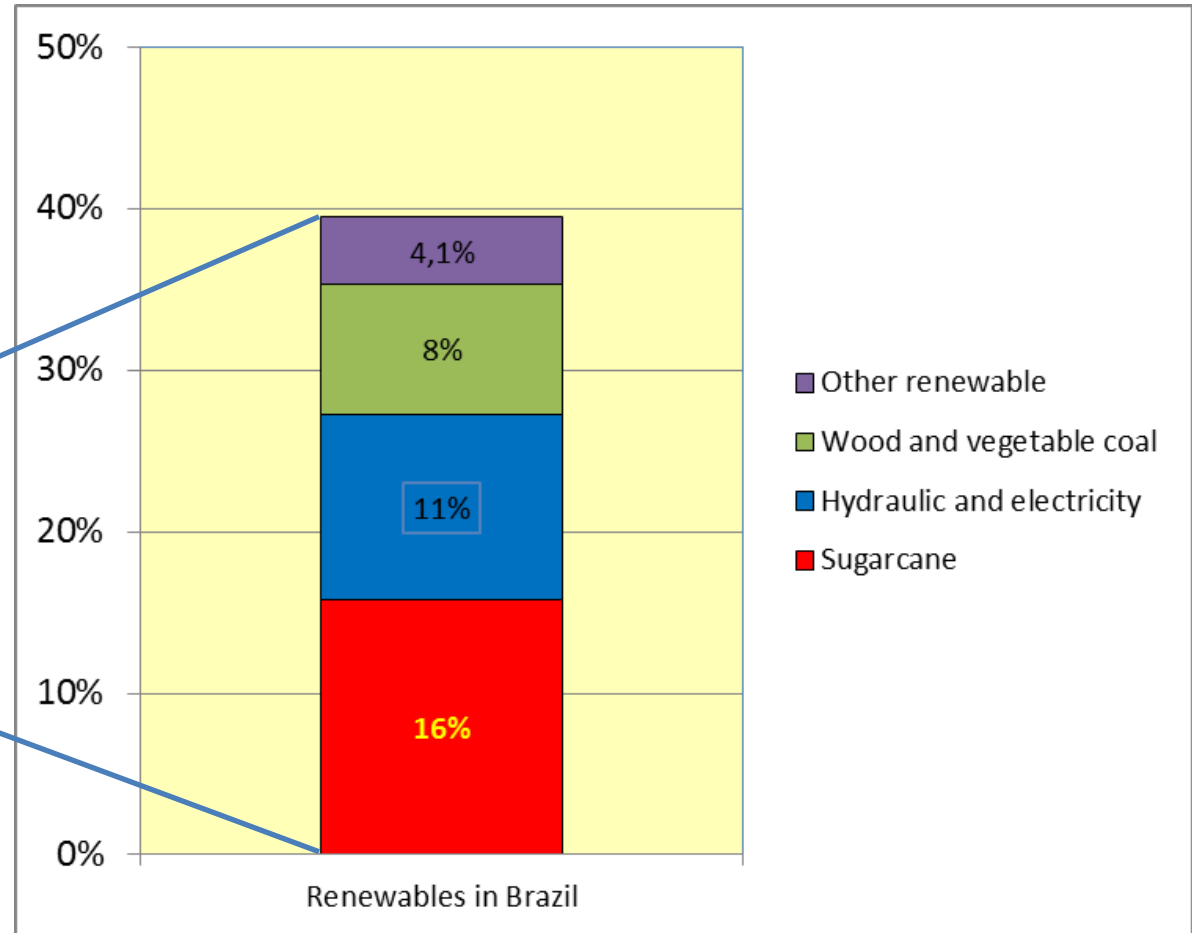
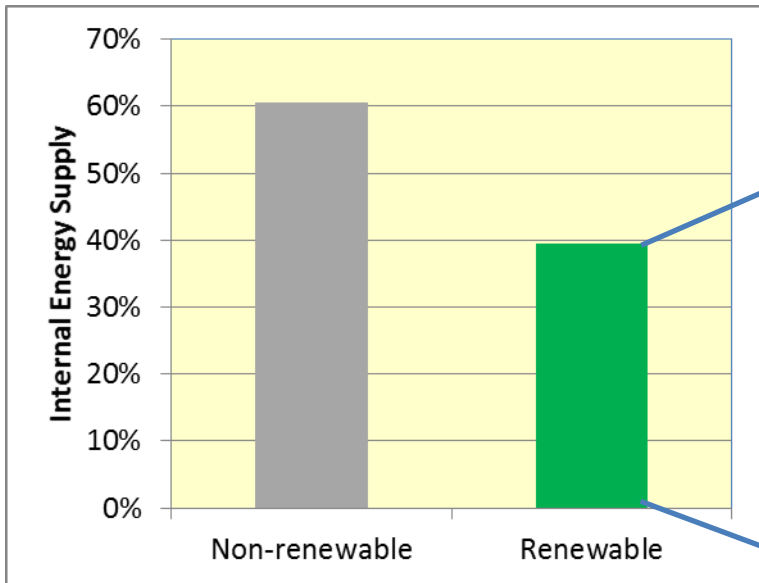

1980-2013: change in energy sources in the State of São Paulo, Brazil

State of São Paulo

- 42 million people
- 32% of Brazil's GNP
- 55% of Brazilian ethanol production

1980 – 2013

- Oil down from 62% to 38%
- Cane up from 14% to 32%

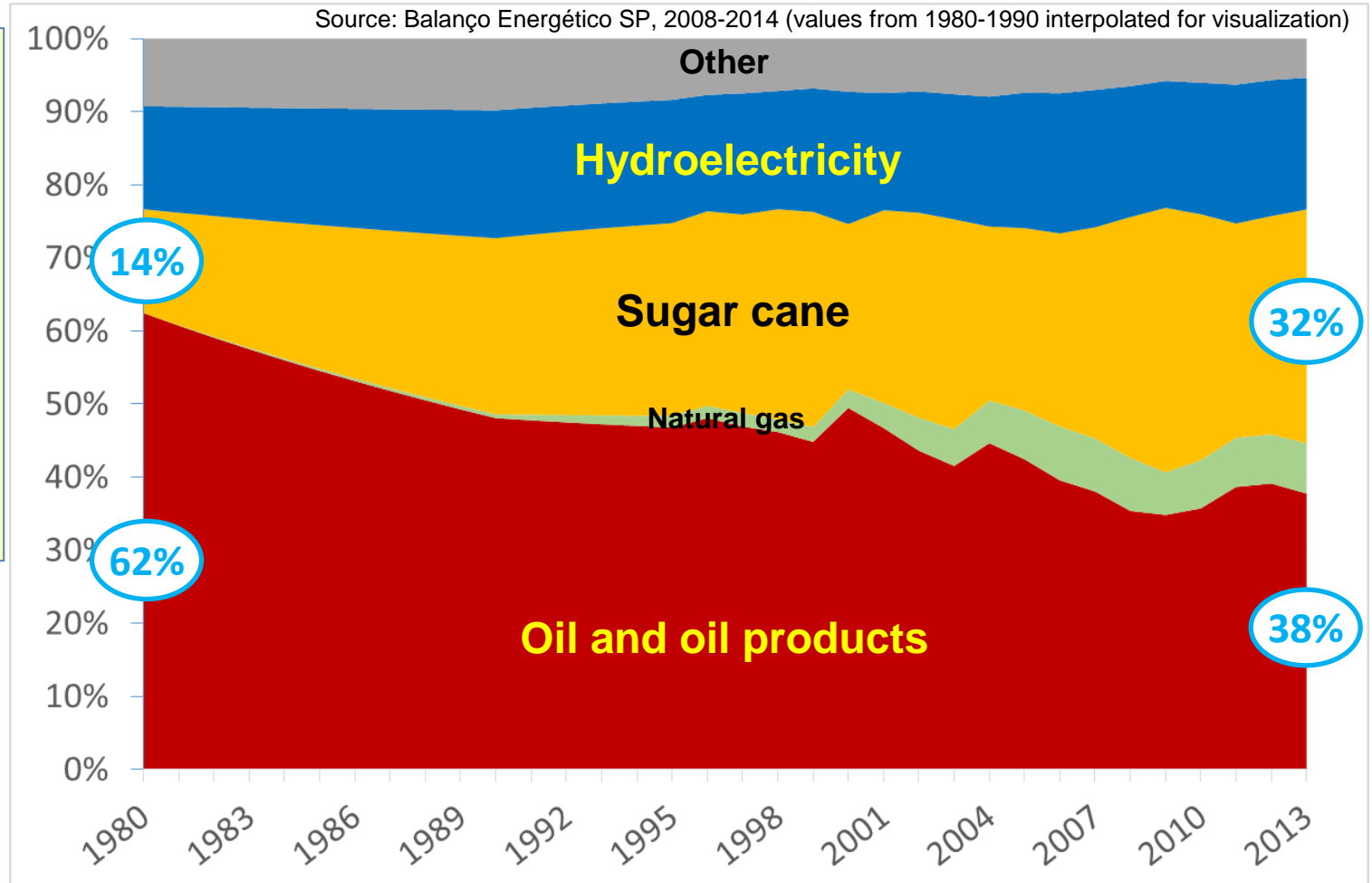

Embraer-FAPESP: R&D to build an innovative jet

Computational Fluid Dynamics
(CFD) simulation and tests
Research co-funded by FAPESP,
using several universities

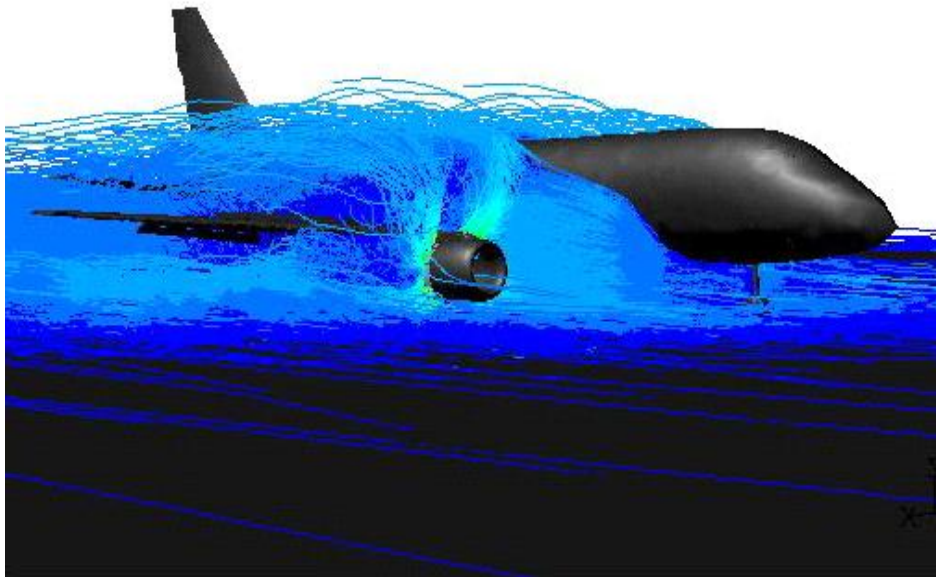

Aerodinâmica, Fluidodinâmica computacional

International Journal for Numerical Methods in Fluids [Explore this journal >](#)

Research Article

Adaptive mesh refinement and coarsening for aerodynamic flow simulations

Leonardo Costa Scalabrin, João Luiz F. Azevedo 

First published: 14 May 2004 [Full publication history](#)

DOI: 10.1002/fld.731 [View/save citation](#)

Cited by: 3 articles [Refresh](#) [Citing literature](#)



[Funding Information](#)

Abstract

A new mesh refinement technique for unstructured grids is discussed. The new technique presents the important advantage of maintaining the original grid skewness, thanks to the capability of handling hanging nodes. The paper also presents an interpretation of MacCormack's method in an unstructured grid context. Results for a transonic convergent-divergent nozzle, for a convergent nozzle with a supersonic entrance and for transonic flow over a NACA 0012 airfoil are presented and discussed. Copyright © 2004 John Wiley & Sons, Ltd.

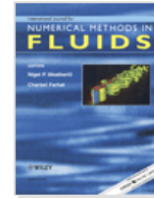

[View issue TOC](#)
Volume 45, Issue
10 August 2004
Pages 1107-11

Navier–Stokes-Based Study into Linearity in Transonic Flow for Flutter Analysis

Roberto G. A. Silva,* Olympio A. F. Mello,[†]
and João L. F. Azevedo[‡]
*Centro Técnico Aeroespacial,
12228-904 São José dos Campos SP, Brazil*

Introduction

IT has been known for quite some time¹ that transonic flow conditions are critical for flutter, with the flutter dynamic pressure being substantially reduced for Mach numbers near unity, in a phenomenon usually termed as “transonic dip.”² The severity of flutter

Ideas might start as abstractions



Pergamon

Int. Comm. Heat Mass Transfer, Vol. 28, No. 7, pp. 963–972, 2001
Copyright © 2001 Elsevier Science Ltd
Printed in the USA. All rights reserved
0735-1933/01/\$—see front matter

PII: S0735-1933(01)00300-1

UNSTEADY HEAT CONDUCTION IN 3D ELLIPTICAL CYLINDERS

M.S. Ferreira and J.I. Yanagihara
Department of Mechanical Engineering
Polytechnic School – University of São Paulo
São Paulo, SP 05508-900, Brazil

ABSTRACT

The main purpose of this paper is to present a numerical calculation procedure for transient heat conduction in a 3D elliptical cylinder. A non-orthogonal analytical transformation converting an elliptical cylinder into a parallelepiped was developed. The finite-volume method was applied to the transformed partial differential equations. The resulting algebraic equations were solved by a technique similar to the alternating-direction-implicit scheme.

...then evolve into a concrete idea that industry can recognize...



Contents lists available at ScienceDirect

International Communications in Heat and Mass Transfer

journal homepage: www.elsevier.com/locate/ichmt



A transient three-dimensional heat transfer model of the human body[☆]

M.S. Ferreira^a, J.I. Yanagihara^{b,*}

^a Department of Mechanical Engineering, FEI (Fundação Educacional Inaciana), São Bernardo do Campo, Brazil

^b Department of Mechanical Engineering, Polytechnic School, University of São Paulo, Av. Prof. Mello Moraes, 2231, 05508-900, São Paulo, SP, Brazil

ARTICLE INFO

Available online 16 April 2009

Keywords:

Human body thermal model
Human thermal system
Bio-heat transfer
Thermoregulation
Thermal comfort

ABSTRACT

The objective of this work is to develop an improved model of the human thermal system. The features included are important to solve real problems: 3D heat conduction, the use of elliptical cylinders to adequately approximate body geometry, the careful representation of tissues and important organs, and the flexibility of the computational implementation. Focus is on the passive system, which is composed by 15 cylindrical elements and it includes heat transfer between large arteries and veins. The results of thermal neutrality and transient simulations are in excellent agreement with experimental data, indicating that the model represents adequately the behavior of the human thermal system.

© 2009 Elsevier Ltd. All rights reserved.

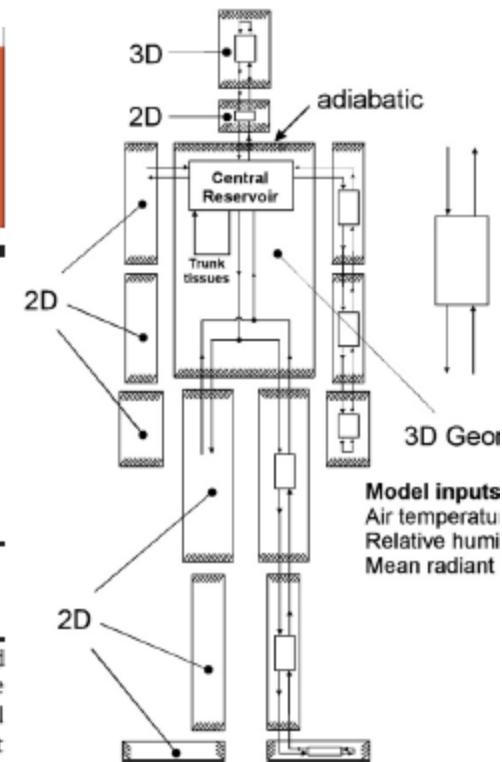

Result: FAPESP-Embraer-Poli, USP Research Center for Comfort Engineering

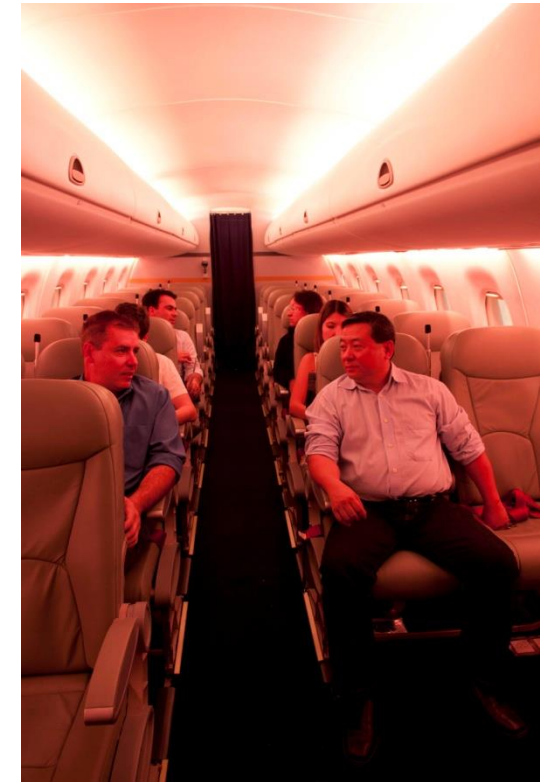
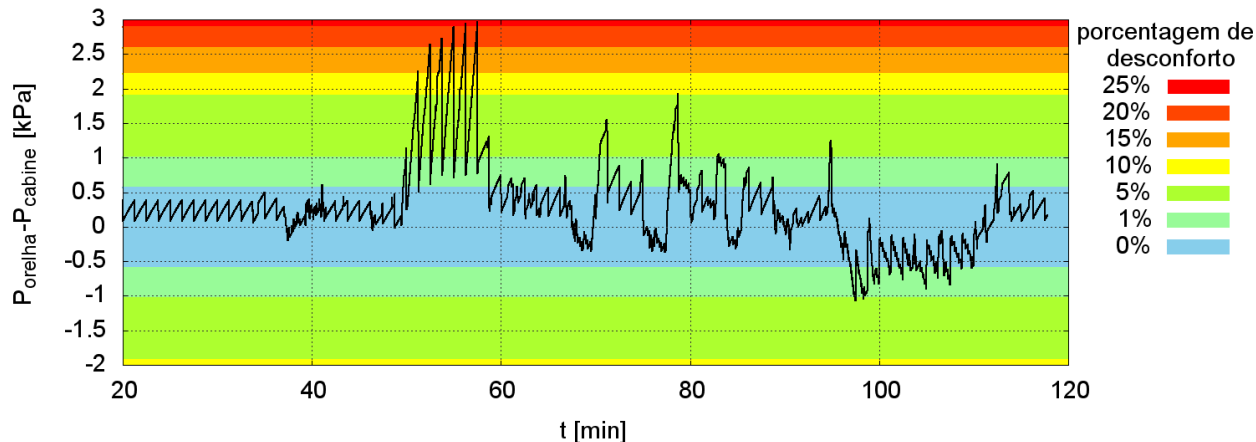
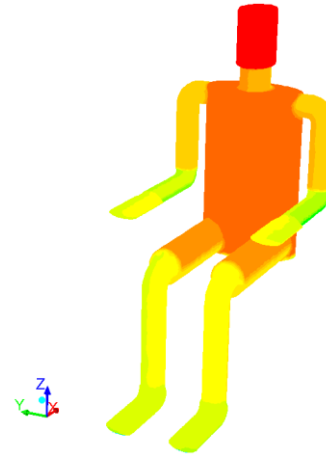
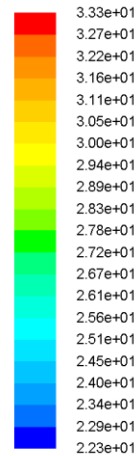
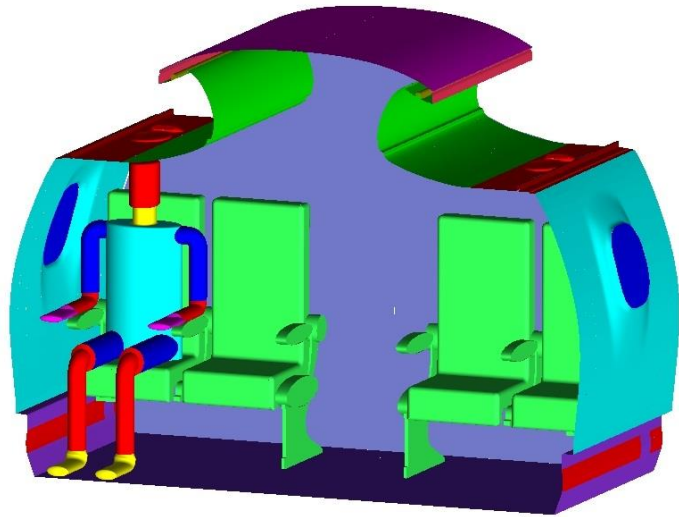

Advanced Molecular Biology for Health and Agriculture



Supported by:

02/25/2015 09h47



Latin America's first kinase laboratory

Center located at Unicamp involves an investment of R\$ 18 million from Fapesp

Unicamp

On March 10, Unicamp will launch the first research center of biology in Latin America (LA) in the area of protein kinases, molecules that are highly required in the pharmaceutical industry due to their signaling characteristics and the regulation of important biological processes. The laboratory, called Biology Center in Protein Kinase, relies on the partnership with São Paulo Research Foundation (Fapesp) and the Structural Genomics Consortium (SGC).

abbvie



FAPESP-Industry-University Engineering Research Centers

- Center is hosted in a university, PI a professor
 - Adjunct Director is a researcher from the company as a visiting professor at the university
 - Other company researchers as visiting professor are more than welcome
- 10 year contract; R\$ 2 – 6 million per year from FAPESP and Company, plus labor costs by university
 - Typical proportion: FAPESP:Industry:University - 1:1:2
- Five Centers selected, 5 in open calls (Shell (4); Statoil (1))
 - Peugeot-Citroen (PCBA)
 - Biofuel Engines Engineering Research Center; hosted at Unicamp (incl. ITA, USP, Mauá); PCBA+FAPESP - R\$ 16 million + in-kind by host univ. (est. R\$ 16 million)
 - GSK
 - Engineering Research Center on Sustainable Chemistry; R\$ 32 million + in-kind by host university
 - Engineering Research Center on Target Discovery; R\$ 32 million + in-kind by host university
 - Natura: Applied Research Center on Well-being and Human behavior
 - R\$ 20 million + in-kind by host university
 - BG: ERC Natural Gas

Centros de Pesquisa Aplicada FAPESP-Empresa-Universidade

Centro	Empresa/ Univ ou Inst. Pg.	Valores contratados
Centro de Pesquisa em Engenharia sobre Motores a Biocombustível	Peugeot-Citroen Unicamp e outras	FAPESP: R\$ 8 M PCBA: R\$ 8 M Unicamp+: R\$ 16 M
Centro de Pesquisa em Engenharia sobre Química Verde	GSK Ufscar e outras	FAPESP: R\$ 5 M GSK: R\$ 5,5 M Ufscar+: R\$ 20 M
Centro de Pesquisa em Engenharia sobre Descoberta de Moléculas Alvo de Origem Natural para Drogas	GSK Inst. Butantan	FAPESP: R\$ 13 M GSK: R\$ 11 M Inst. Butantan: R\$ 33 M
Centro de Pesquisa em Engenharia sobre Gás Natural	British Gas Polij, USP e outras	FAPESP: R\$ 27 M BG: R\$ 30 M USP+: R\$ 43
Centro de Pesquisa Aplicada sobre Bem Estar Humano	Natura Inst. Psicologia, USP+	FAPESP: R\$ 10 M Empresas: R\$ 10 M Univ/Inst.: R\$ 20 M

FAPESP+Peugeot-Citroen: Advanced Research Center for Biofuel Engines

- 10year contract
- Unicamp, USP, Mauá, ITA
- Researchers from universities and from company
 - Vice-director is a Company scientist
- Other 4 ERCs:
 - Natura
 - Glaxxo-Smith-Kline, GSK
 - Green Chemistry
 - Target Discovery
 - British Gas, BG

FAPESP inaugura Centro de Pesquisa em parceria com a PSA Peugeot Citroën



Iniciativa apoiará o desenvolvimento de motores movidos a biocombustíveis com participação de pesquisadores da USP, Unicamp, ITA e Instituto Mauá de Tecnologia

A Fundação de Amparo à Pesquisa do Estado de São Paulo (FAPESP) e a PSA Peugeot Citroën do Brasil anunciaram ontem, dia 04 de novembro de 2014, na sede da FAPESP, o lançamento do Centro de Pesquisa em Engenharia "Professor Urbano Ernesto Stumpf", para desenvolvimento de motores de combustão interna, adaptados ou desenvolvidos especificamente para biocombustíveis e de estudos sobre a sustentabilidade dos biocombustíveis.

FAPESP-BG Brasil-Poli, USP: Engineering Research Center on Natural Gas

FAPESP e BG Brasil selecionam Centro de Pesquisa para Inovação em Gás Natural

30 de julho de 2015



Agência FAPESP – A FAPESP e a BG Brasil, empresa do BG Group, anunciam o resultado da seleção de uma proposta para implantação do Centro de Pesquisa para Inovação em Gás Natural (CIG).

O projeto será coordenado por Julio Meneghini, professor do Departamento de Engenharia Mecânica da Escola Politécnica da Universidade de São Paulo (Poli-USP) e pesquisador principal do Centro, e por Alexandre Breda, gerente de Projetos Ambientais do BG Group. A sede será na Poli/USP, responsável pelo apoio institucional e administrativo aos pesquisadores envolvidos.

A seleção da proposta foi feita com base em pareceres de assessores no Brasil e no exterior sobre as propostas apresentadas em resposta a Chamada Pública, lançada no âmbito do acordo de cooperação assinado entre a FAPESP e a BG Brasil em setembro de 2013.

O CIG contará com apoio de longo prazo da FAPESP, BG Brasil e da USP para desenvolver pesquisa científica de classe internacional nas áreas de Engenharia, Física e Química e em Políticas Energética e Econômica. O contrato entre as instituições será assinado nos próximos meses, celebrando a implantação do CIG.



Proposta selecionada em chamada propõe ampliar a participação do gás natural na matriz energética (foto: BG Group)

Glaxo Smith Kline (GSK) and FAPESP

- GSK-FAPESP Center for Green Chemistry
 - Federal Univ. S. Carlos; with Unicamp, USP-RP, UNESP, UFSC
 - Reducing environmental impact in organic synthesis
 - Use of sustainable solvents, energy sources, safer reactants, cleaner processes, renewable feedstocks

FAPESP Funding:	R\$ 5,094,554.59
GSK Funding:	R\$ 5,490,642.06
UFSCAR Funding:	R\$ 20,378,752.10



CERSusChem
Centre of Excellence for
Research in Sustainable Chemistry

A new Synchrotron Light Source

Sirius main parameters

Electrons energy	3 GeV
Circumference	518.2 m
Natural emittance without IDs	0.28 nm.rad
Maximum current	500 mA



a nova fonte de luz síncrotron brasileira



LNLS is currently engaged in the development and construction of **Sirius**, a new **3 GeV** synchrotron light source, designed to be one of the most advanced in the world. Its **ultra-low emittance** (0.28 nm.rad) and **high brightness** will allow the execution of very competitive experiments, opening new perspectives for research in fields such as material science, structural biology, nanoscience, physics, earth and environmental science, cultural heritage, among many others. Sirius will be located inside **CNPEM campus**, next to the UVX current storage ring building ([see the location here](#)). For Latin America, the construction of Sirius represents a major leap into the future of synchrotron science.

Pesquisa Inovativa na Pequena Empresa

– PIPE FAPESP

- Pesquisa na pequena empresa
 - potencial de retorno comercial
 - aumento da competitividade da empresa
 - estimular a criação de “cultura de inovação permanente” (FAPESP 1997)
- Condições
 - não se exige contrapartida
 - Empresas com menos do que 250 empregados
 - até R\$ 1.250.000 por projeto
 - pesquisador principal deve ser vinculado à empresa
- Seleção
 - Comitês com pesquisadores de empresas e acadêmicos
 - Coordenação de Área - Pesquisa para Inovação

PIPE FAPESP: praticamente 1 projeto / dia útil em 2016

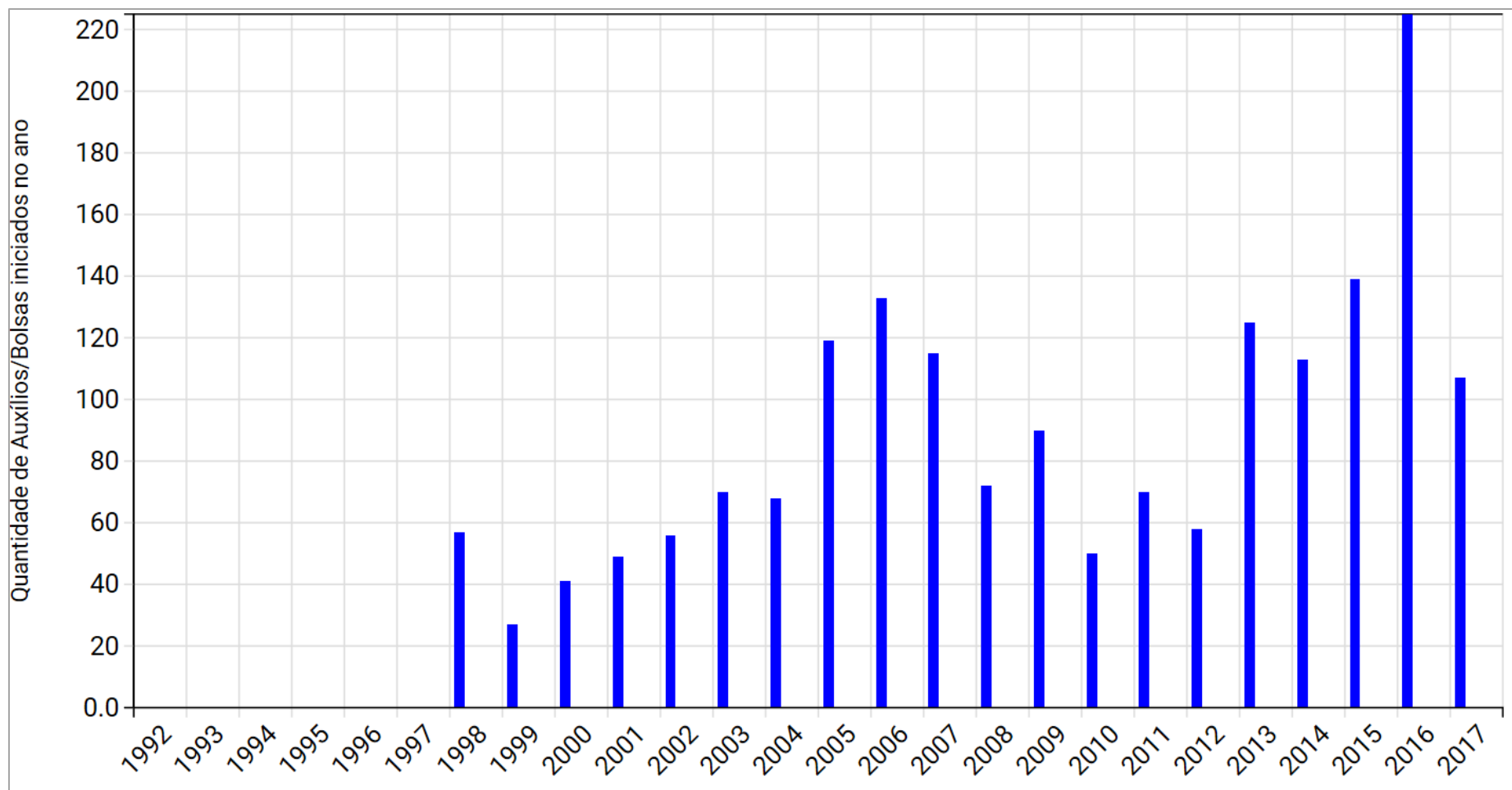

FAPESP: valor contratado em Auxílios

PIPE, 1992-2016

Pesquisa em Empresas de Pequeno Porte

Série temporal por linhas de fomento e por áreas do conhecimento

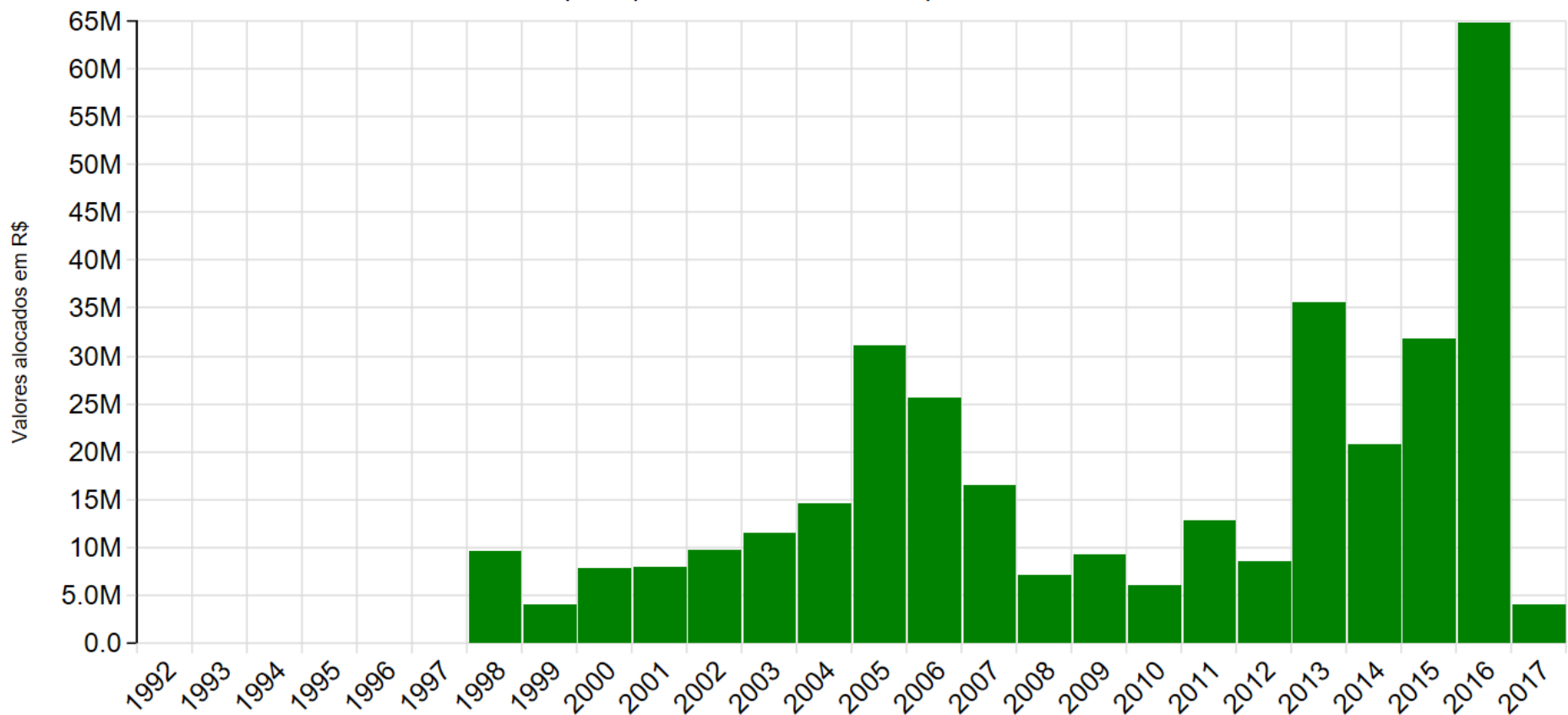

Localização dos projetos boas universidades atraem PE

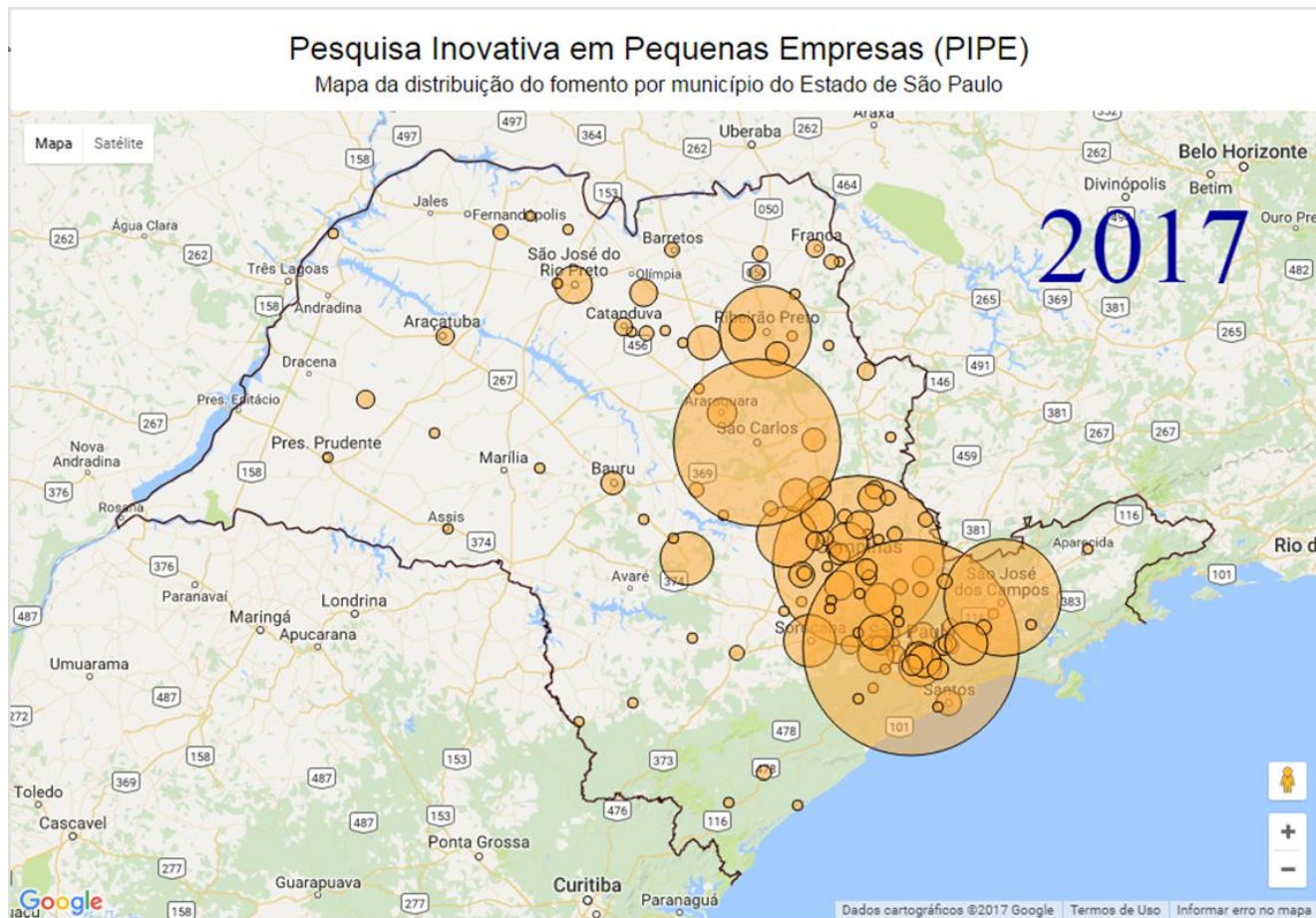

Munic.	Qtd
SP	359
Campinas	224
S. Carlos	220
SJCampos	129
Rib. Preto	98
Piracicaba	28
Botucatu	23

Avaliação do Programa PIPE ***Dep. Política C&T Unicamp***

Evaluation of ST&I programs: a methodological approach to the Brazilian Small Business Program and some comparisons with the SBIR program

**Sergio Salles-Filho, Maria Beatriz Bonacelli, Ana Maria Carneiro,
Paula F Drummond de Castro and Fernando Oliveira Santos**

Research Evaluation, 20(2), June 2011, pages 159–171

DOI: 10.3152/095820211X12941371876184; <http://www.ingentaconnect.com/content/bee/rev>

PIPE FAPESP e SBIR NSF

Table 2. Similarities between PIPE and SBIR

Indicators	PIPE	SBIR
Revenues derived from the projects	40%	40%
Revenues of the 5% biggest firms	R\$20 to 5 million	US\$ 25 million
Projects with patents	29%	30%
Projects that would not be developed without the support of PIPE/SBIR	1/2	2/3
Projects that get more financial resources other than PIPE/SBIR grants	52%	56%

PIPE FAPESP e SBIR NSF

PIPE FAPESP

- 85% das empresas usaram conhecimento ou Tecnologia de universidades, especialmente as públicas
- 53% tem Relações informais com universidades
- 75% usam equipamentos de universidades

SBIR NSF

- 33% das empresas tem interação com universidades
- 67%+ tem um fundador vindo da academia

PIPE connected to Technology Challenges in São Paulo

- PIPE Venture: Fundo de Inovação Paulista (FIP)
 - Liderado por DesenvolveSP, participação FAPESP
 - DesenvolveSP, FAPESP, FINEP, SEBRAE, CAF
- PIPE-PAPPE Advanced Manufacturing - call closed; 24 proposals
- PIPE-PAPPE Sirius: suppliers for the new Brazilian Synchrotron Light Source (Sirius) - Two Calls for Proposals
 - LNLS: established the science and technology challenges
- PIPE-PAPPE Tecnologia Espacial – call closed on 04/Apr/2016
- PIPE-PAPPE Zika virus and Aedes – call closed 02/Apr/2016
- PIPE-PAPPE Sustainable and Intelligent Cities – call closed 23/May/2016
- PIPE-PAPPE Aplicativos para Produtividade no Setor Agropecuário – call closed 20/04/2017
- PIPE-PAPPE Combate a Arboviroses – deadline em 14/07/2017
- PIPE traditional Call for Proposals: 3/2016: 01/08/2016

Utilizando softwares exclusivos baseados no estado da arte do controle avançado e da inteligência artificial, a I.Systems traz estabilidade e eficiência aos processos industriais de seus clientes. Em pouco mais de 5 anos foram mais de 60 aplicações em diferentes equipamentos e mais de 25 grupos atendidos em diversos setores.

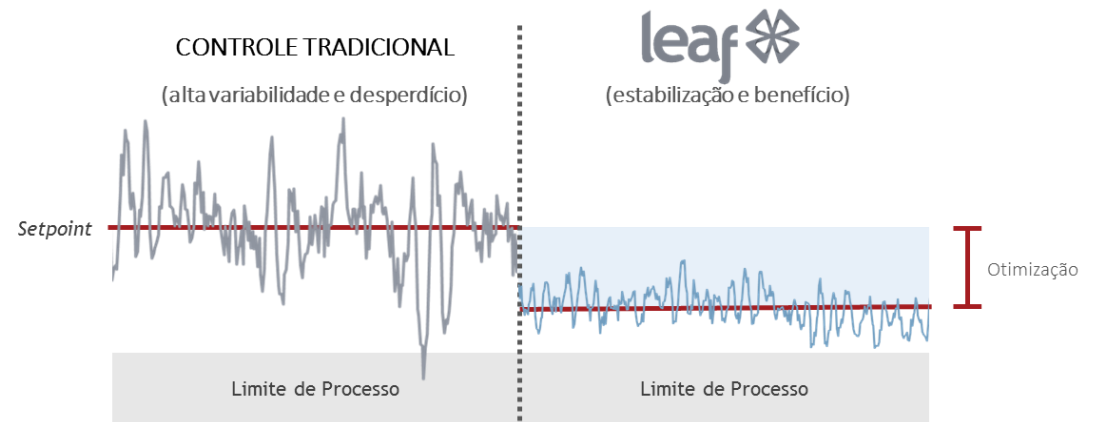
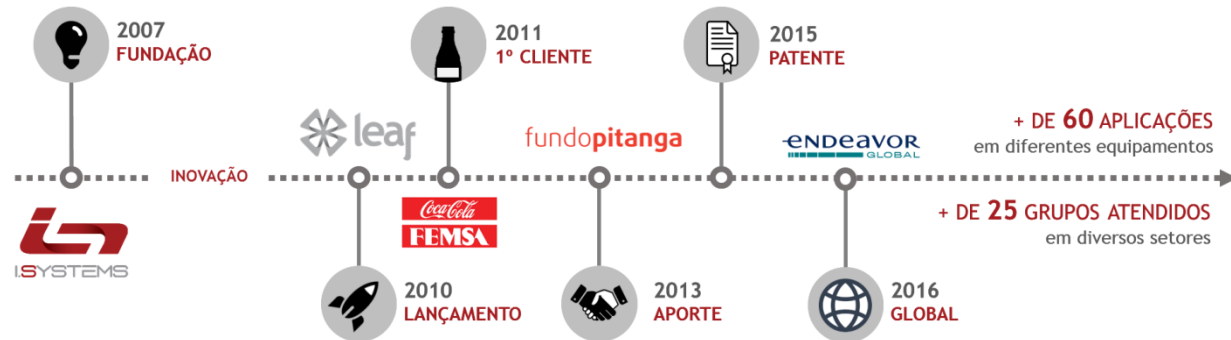

Mais Leve que o Ar



A ALTAVE foi criada por engenheiros qualificados com experiência internacional e desenvolve veículos mais leves que o ar, com foco em serviços inovadores. A ALTAVE esta localizada no DCTA, em São José dos Campos, e possui parcerias com o ITA, IAE, IPEV e IFI. A ALTAVE hoje é fabricante sem similar nacional de aeróstatos cativos para monitoramento e radiocomunicações.

Omnisys: São Caetano

Radares, 250 funcionários

- Operações em 9 países
- 250 funcionários
- 70 técnicos e engenheiros no departamento de P&D
- Investimentos médios anuais de 15% da sua receita em P&D

Parceiros:
 Unicamp
 IPT; USP
 ITA; FEI
 CTA; IPqM
 CLA, INPE

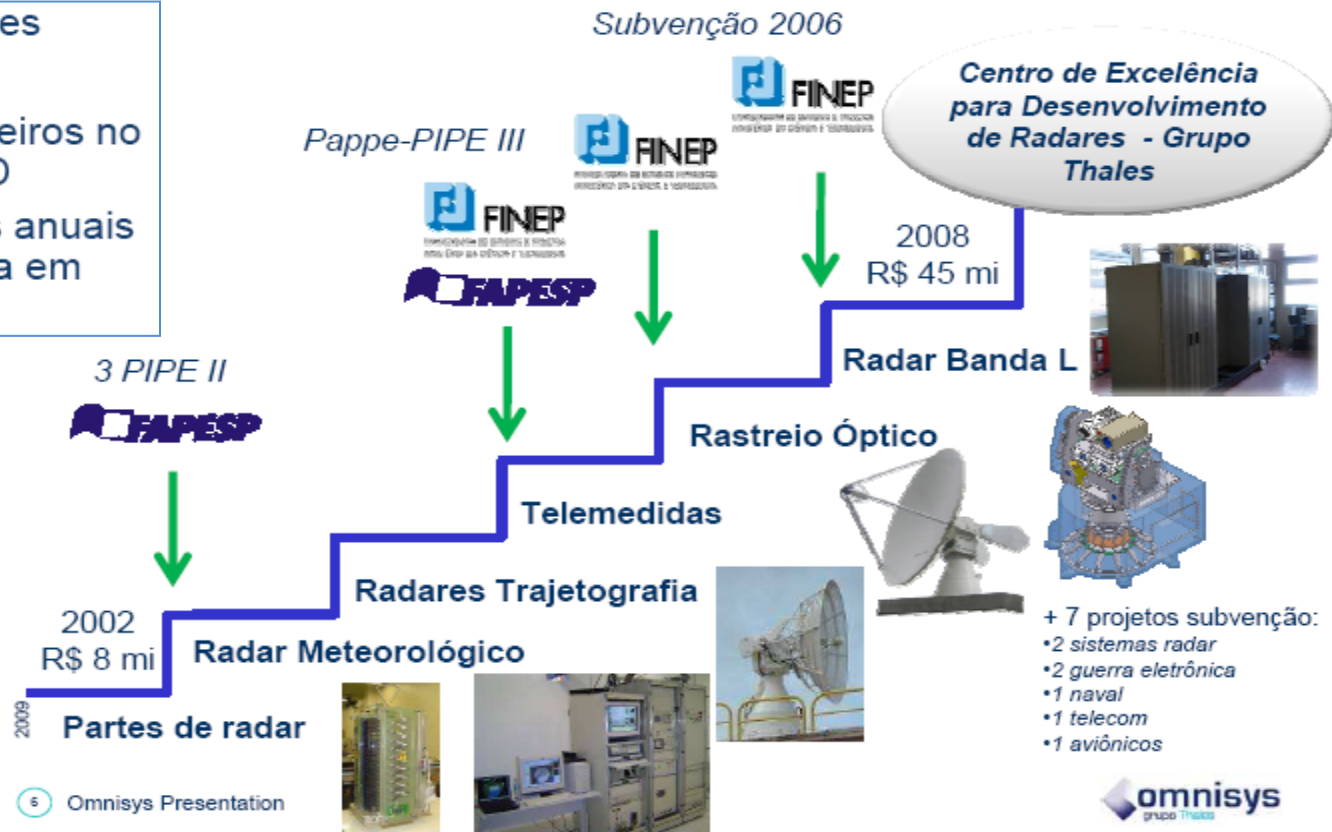

Controle de Pragas e Endemias

A BR3 desenvolve tecnologias em química e biotecnologia voltadas para aplicações na agricultura e na saúde pública. Em 2001, a BR3 lançou o fungicida Fegatex, a partir de um ingrediente ativo de uso inédito no mundo. É um produto extremamente interessante no manejo fitossanitário e possui registro para as culturas de batata, café, cenoura, citros, feijão, maçã, milho, soja e tomate. A empresa também desenvolveu, uma linha de larvicidas para controle de vetores da dengue, malária e filariose, a partir de tecnologia licenciada pela **FIOCRUZ**. O DengueTech é o **mais eficaz inseticida biológico** contra os vetores da Dengue, Zika e Chikungunya.



Embalagens Plásticas Bactericidas

A Nanox é uma empresa criada por pesquisadores de um dos CEPIDs da Fapesp, que desenvolveram materiais bactericidas para embalagens plásticas de alimentos, já aprovada pelo FDA para comercialização nos Estados Unidos. A empresa também foi selecionada pelo Global Entrepreneurship Lab (G-LAB), do MIT, para desenvolver um plano de negócios voltado ao mercado norte-americano. O novo material bactericida é mais uma aplicação da linha de antimicrobianos inorgânicos – batizada de “NanoxClean” –, que a empresa vem desenvolvendo desde 2005, com apoio do Programa PIPE da Fapesp.



A BrP fornece dispositivos optoeletrônicos para transceptores e sistemas integrados. Através de tecnologias avançadas, a BrP prevê a convergência entre fotônica e microeletrônica para transmissões a partir de 100 Gb/s através de links ópticos de menor consumo de energia e maior densidade.

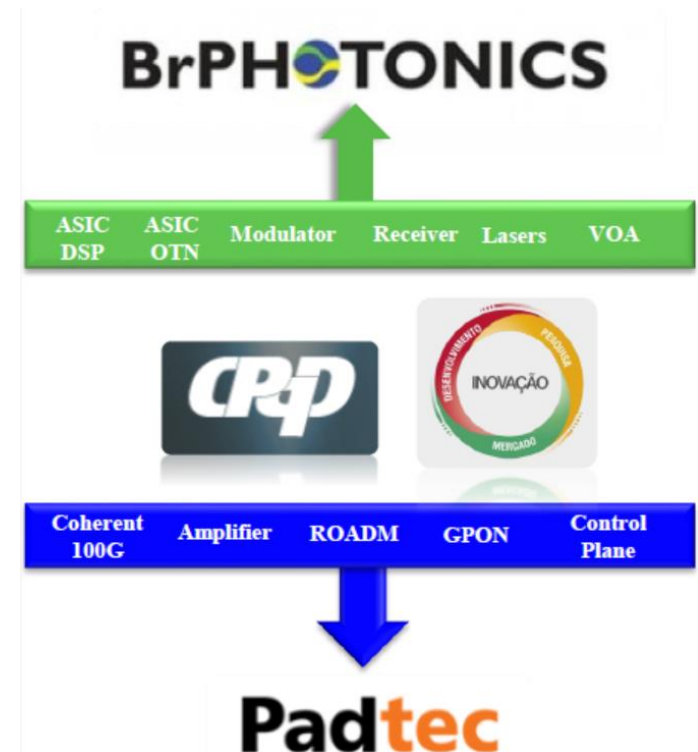

GIGOPTIX AND CPQD FORM JOINT VENTURE BRPHOTONICS IN BRAZIL

(02/26/2014)

By: Semiconductor Today

GigOptix of San Jose, CA, a fabless supplier of analog semiconductor and optical communications components for fiber-optic and wireless networks, and CPqD, an independent Brazil-based research center focused on information and communication technologies with activities in system- and device-level optical communications, have agreed to form the joint venture BrPhotronics Produtos Optoeletronicos LTDA of Campinas, Brazil. Both partners will transfer into BrPhotronics their knowledge-base and intellectual property of existing technologies, and will jointly work through the partnership to enhance, develop and commercialize products based on them. GigOptix will transfer to Brazil its Thin Film Polymer on Silicon (TFPS) technology, inventory related to the TFPS platform, and all the production line equipment currently at its facility in Bothell, WA. CPqD will transfer to BrPhotronics its silicon photonics (SiPh) technology, optical packaging expertise, and design and testing capabilities.

Record distance: 140 km link using TFPS CPqD and BrPhotonics @ ECOC 16

50-GHz+ Thin-Film Polymer on Silicon Modulator for PAM4 100G-per-wavelength Long-Reach Data Center Interconnects

Andrea Chiuchiarelli⁽¹⁾, Sandro M. Rossi⁽¹⁾, Valery N. Rozental⁽¹⁾, Glauco C.C.P. Simões⁽¹⁾,
Luis H.H. Carvalho⁽²⁾, Júlio C.R.F. Oliveira⁽²⁾, Juliano R.F. Oliveira⁽¹⁾, Jacklyn D. Reis⁽¹⁾

⁽¹⁾CPqD, Division of Optical Technologies, Campinas-SP, 13902-086, Brazil,

⁽²⁾BrPHOTONICS, Campinas-SP, 13086-902, Brazil.

Abstract This paper demonstrates 50-GHz+ Mach-Zehnder modulator on Silicon platform for Data Center Interconnects. System level demonstration is 40×112 Gb/s, 56-GBd PAM4 optical channels in 100-GHz WDM grid over re

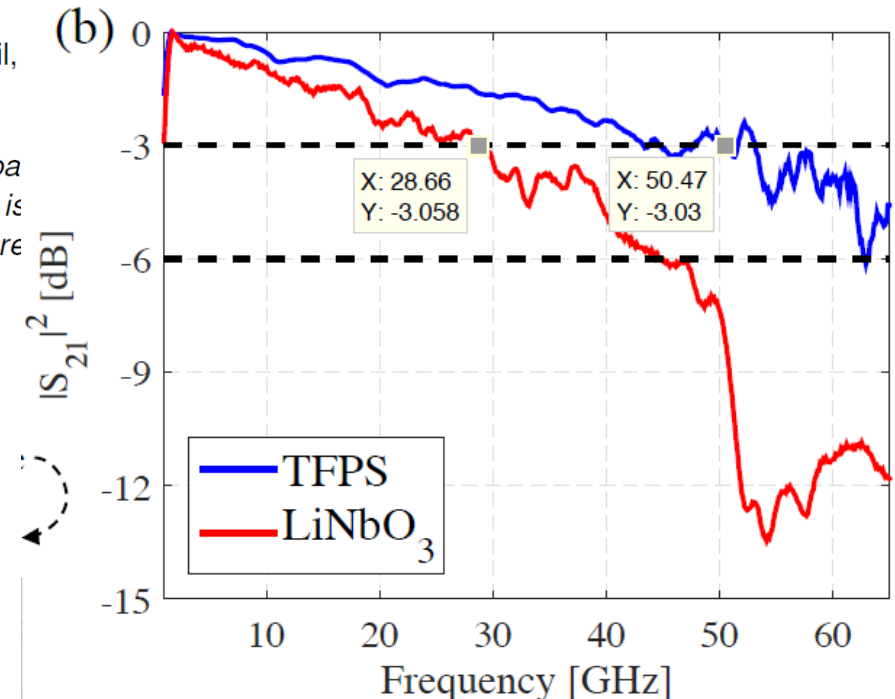

Comunicações Ópticas em Campinas: fluxo de pessoas e ideias

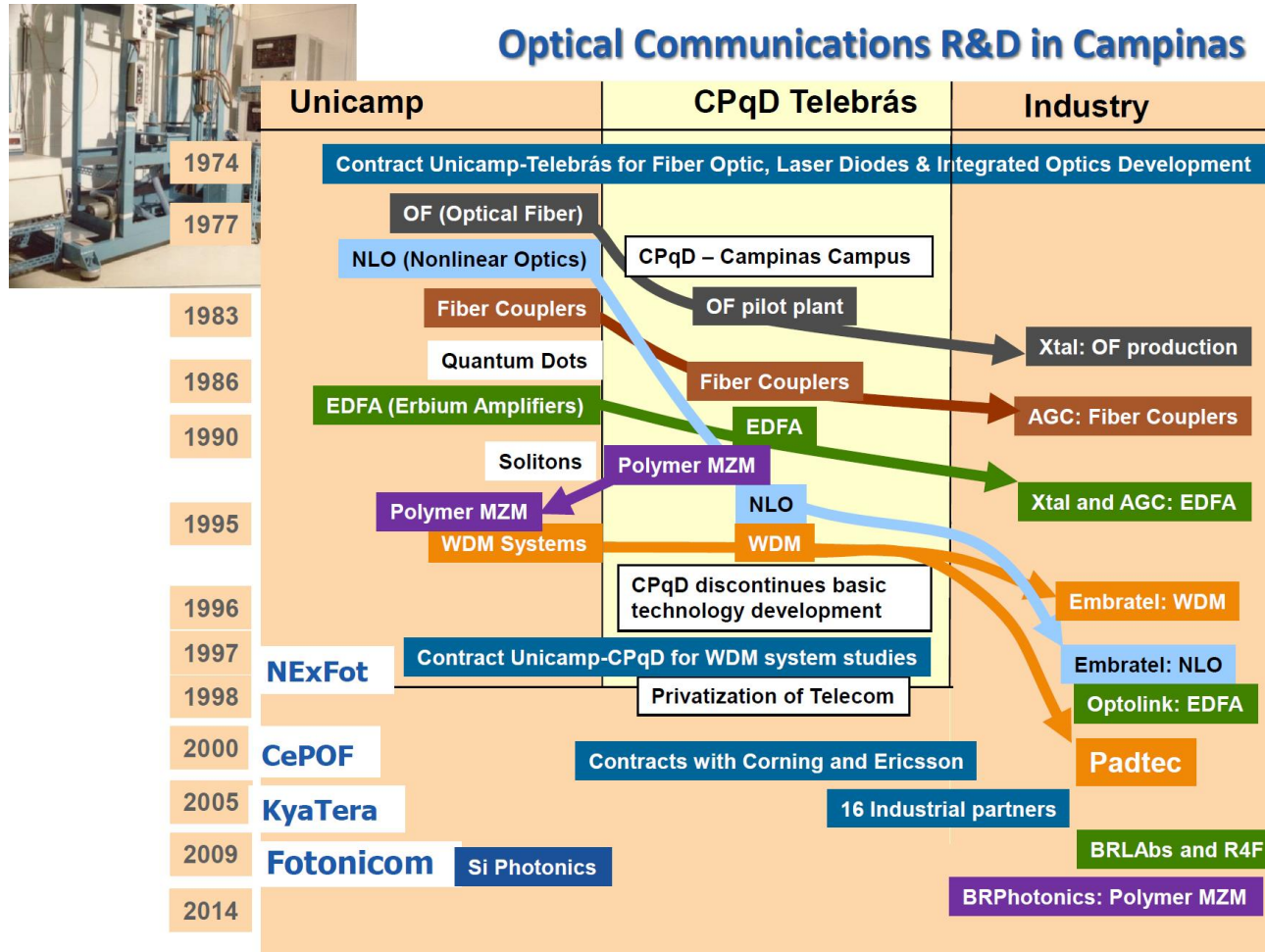

Unicamp 454 start-ups; cerca de 22 mil empregos, fat. R\$ 3 bilhões



Opportunities for foreign scientists in SP: Post-doctoral fellowships

- Three to Five years duration
 - Brazilian or Foreign
 - Stipend
 - Support for moving and installation and Travel for awardee and his family
 - Plus 15% for research incidentals (travel, small equip.)
 - Plus possible scholarship for 1 year abroad
- 2,313 proposals, 1.074 awards in 2013
 - 46% success rate
 - 1,900 fellowships paid in Mar. 2013
 - FAPESP looks for candidates from any country and nationality
- Find opportunities
 - Open positions at <http://www.fapesp.br/oportunidades/en/>
 - Or contact a supervisor to submit a proposal

Opportunities for foreign scientists in SP: Young Investigator Awards

- Targets researchers with 3-5 years post-doctoral experience outside Brazil
 - Open to Brazilians and non-Brazilians
- 4-years grant, extendable for 1-year
 - Typical value ranges from US\$ 200 th to US\$ 2 million
 - Fellowship for PI (including travel and installation)
 - Equipments
 - Consummables
 - Travel
 - Fellowships for students
- 5,132 proposals, 1,350 awards since 1996
 - 347p/72a in 2013 (20% success rate; 3 awards every 2 weeks)
- Info at <http://www.fapesp.br/en/4479>

FAPESP international collaboration: bringing foreign scientists to SP

- Post doctoral fellowships (671 new awards in 2015)
 - Stipend, travel, some research money
- Young Investigator Awards (60 new awards in 2015)
 - Stipend, travel, full research support in a 4-year grant
- Visiting scientists
 - 275 in 2010 (travel, stipend; 2 weeks to 12 months)
- São Paulo Schools of Advanced Science (SPSAS)
 - Each one brings 50-100 young Dr students from abroad
- São Paulo Excellence Chairs (SPEC)
 - For senior level scientists from abroad: full research grant for staying 12 weeks per year in SP for 3-5 years

Manufatura Avançada

- Convite a empresas para parceria em Centro de Pesquisa de 10 anos
- Temas em Manufatura Avançada

To know about research in São Paulo: FAPESP Newsletter – in English

- <http://agencia.fapesp.br/en/>

Agência **FAPESP** NEWS VIDEOS SUBSCRIBE

FAPESP Week 2016 set to celebrate cooperation between scientists in Brazil and the US

Milky Way expanded from inside out
Study by team including Brazilian scientists published in *The Astrophysical Journal Letters* shows that formation of the galaxy's stars began in the center and then spread outwards.

For the latest news in Brazilian scientific research
Subscribe to Agência FAPESP

Interview with Andre Geim | Nobel Prize in Physics 2010

Respirator mask reduces effects of pollution on the heart

Novel biomarker technique gauges field success of insect that parasitizes crop pests

Washington seminar scrutinizes reduction in Brazilian inequality

Dengue Chikungunya

Promising strategies to combat AIDS pandemic

SEE ALL NEWS

Agência FAPESP in social media

Newsletter Agência FAPESP
Sign up for the Agência FAPESP Newsletter. It's free.

20150428 espc-2015 <http://agencia.fapesp.br/home/> 50

FAPESP: Basic Science Focus

- In the World and in Brazil there is in an “utilitarian” view about Science
 - Science that makes business more competitive
 - Science that heals the sick
 - Science that makes the poor rich
- In addition, FAPESP also values
 - Science that makes mankind wiser
 - In all fields there are fundamental questions
 - Philosophy, Archeology, Literature, Linguistics, High Energy Physics, Cosmic Rays, Astronomy, Evolution,..

FAPESP expenditures, 2015

Total: R\$ 1.188 billion

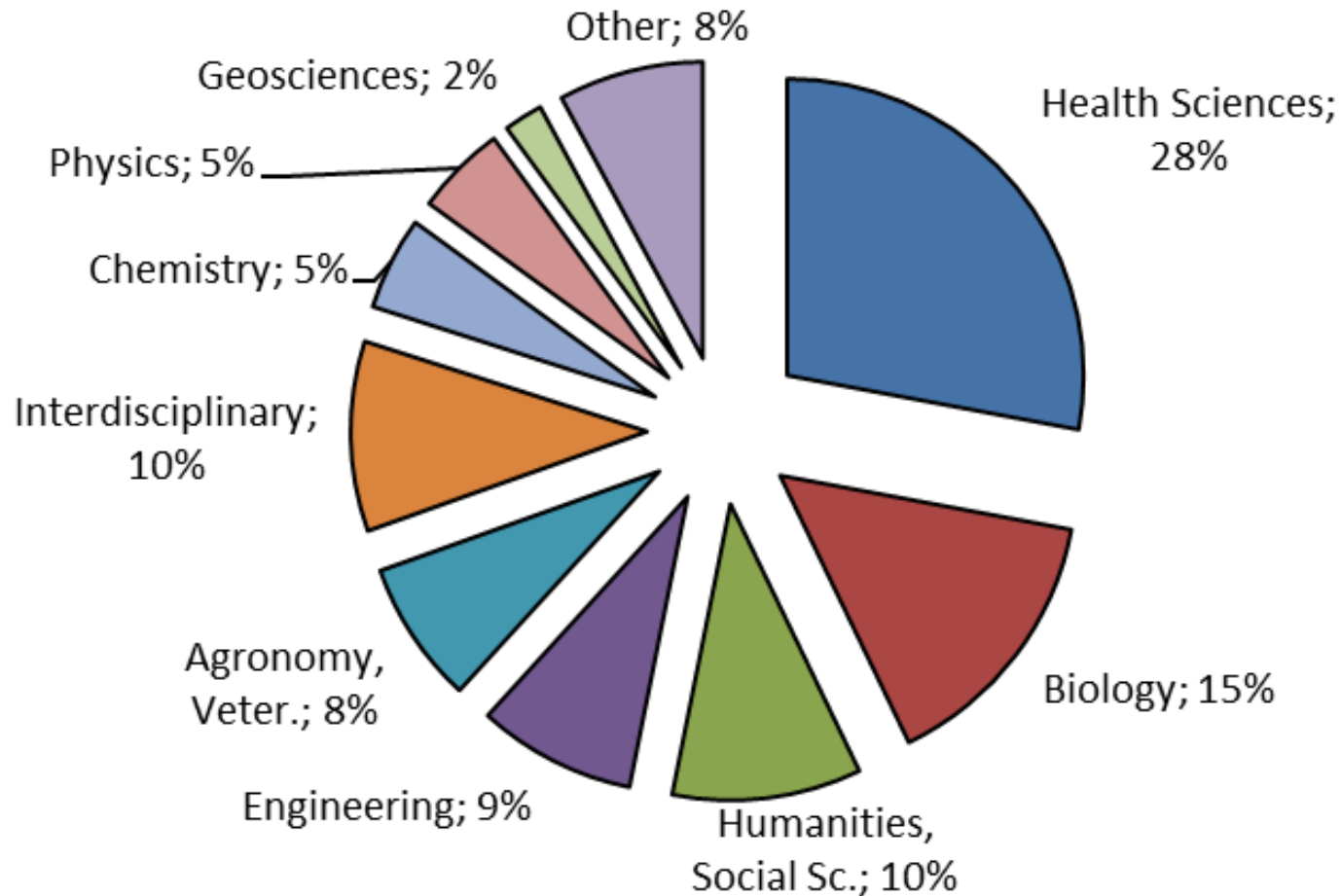

Brazil: 206 million people, 7th GDP



Brazil



© MAGELLAN GeographixSM Santa Barbara, CA (800) 929-4627

PhDs graduated yearly Brazil, UK, Japan, S. Korea

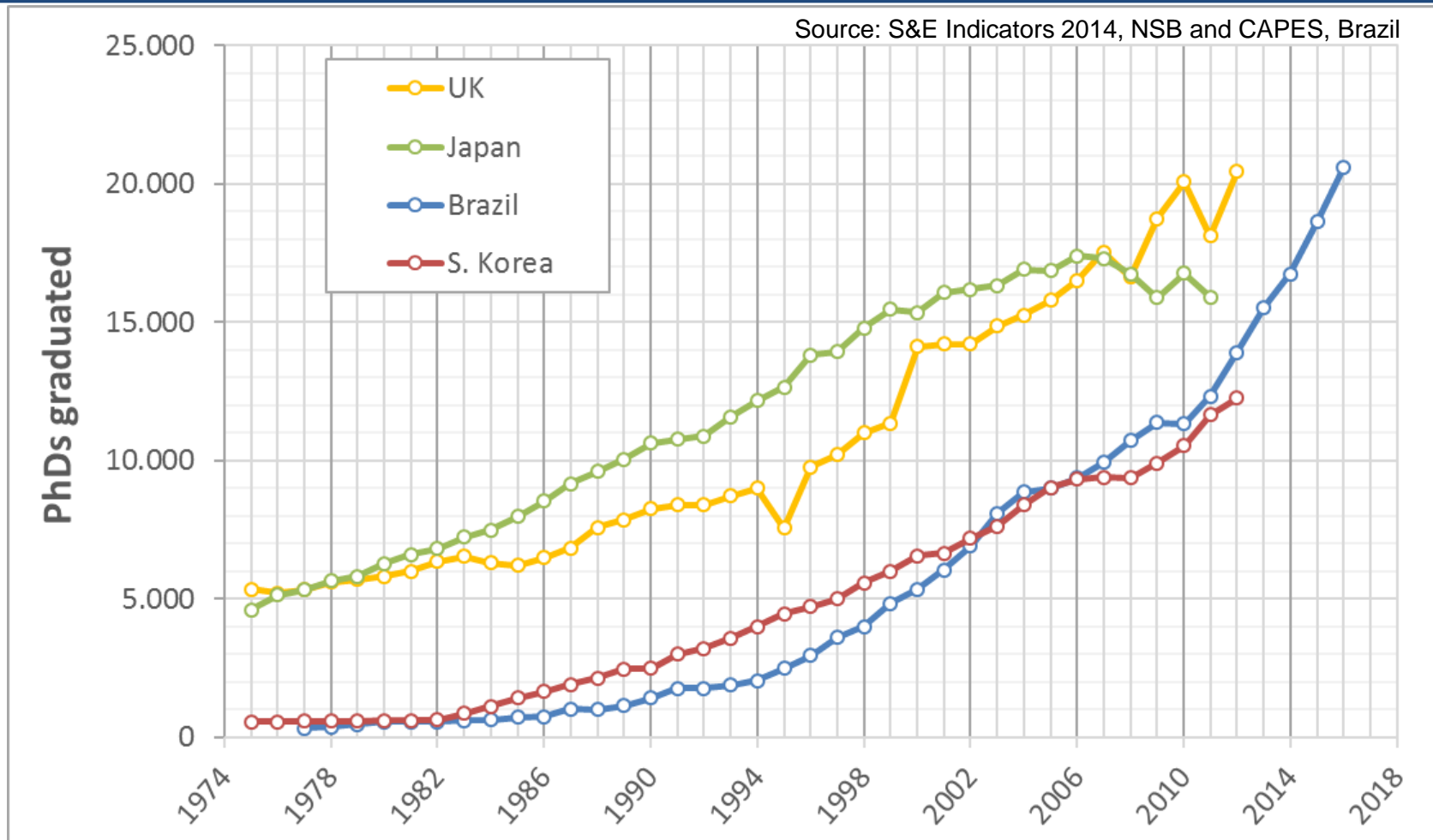

State of São Paulo, Brasil



- 42 Million people
- 32% of Brazil's GDP
- 45% of Brazilian science
- 13% of State budget to HE and R&D
- 1.7% GDP for R&D (2014)
- 3 State Universities
- 3+1 Federal H.E. institutions
- 52 State Tech Faculties
- 39% of the PhDs graduated in Brazil (7,252 in 2016)
- 22 Research Institutes (19 state/3 federal)

PIPE FAPESP e SBIR NSF

Table 3. Differences between PIPE and SBIR

Indicators	PIPE	SBIR
Firms that were created to receive PIPE/SBIR funds	12%	20%
Projects that received venture capital	12%	25%
Commercial exploration of intellectual property rights	4%	16%

Value of FAPESP new contracts in Chemistry, by year

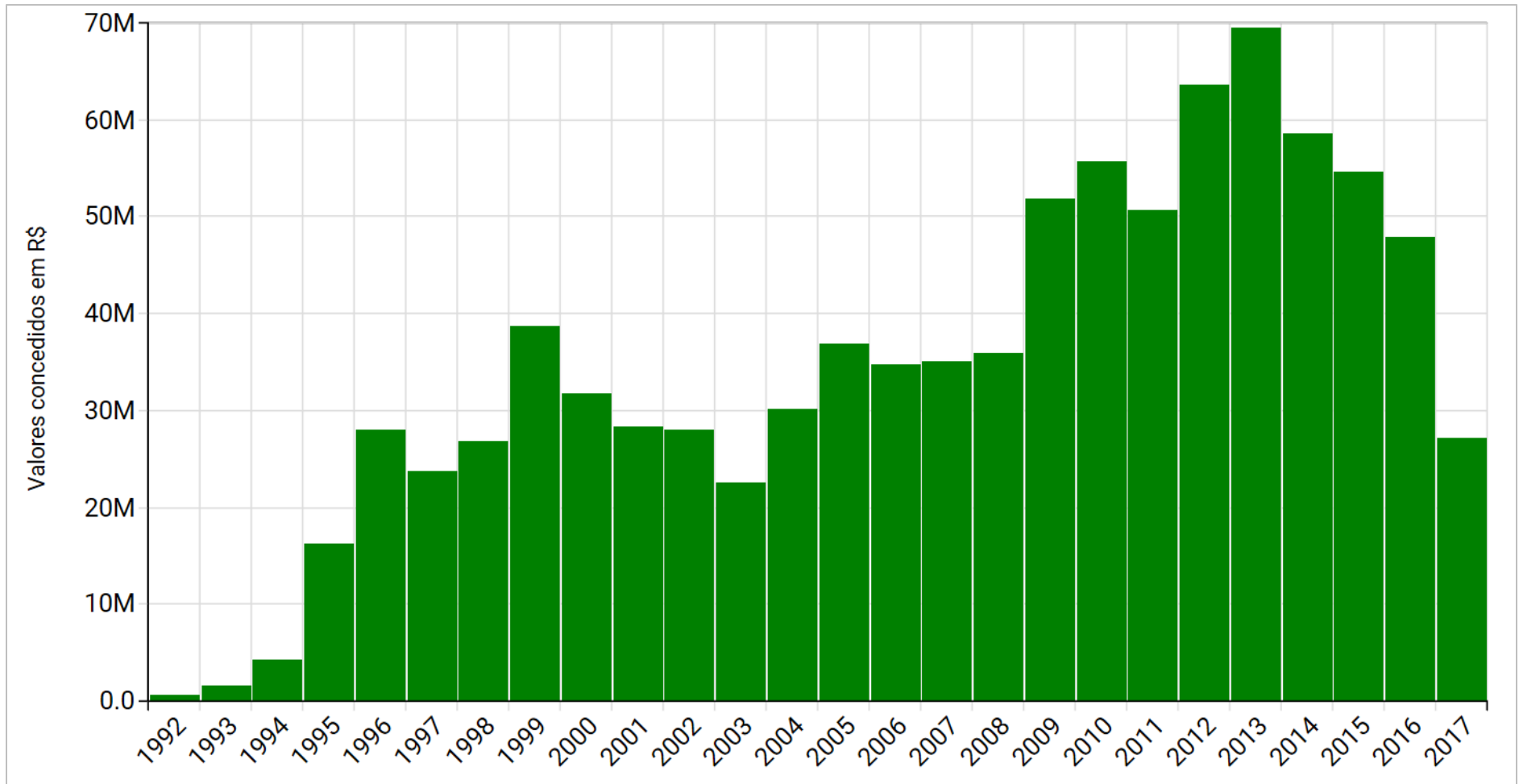

How did Man come to America?

Testing Evolutionary and Dispersion Scenarios for the Settlement of the New World

Mark Hubbe^{1*}, Walter A. Neves², Katerina Harvati³

¹Instituto de Investigaciones Arqueológicas y Museo, Universidad Católica del Norte, San Pedro de Atacama, Chile, ²Laboratório de Estudos Evolutivos Humanos, Departamento de Genética e Biologia Evolutiva, Instituto de Biociências, Universidade de São Paulo, São Paulo, Brazil, ³Paleoanthropology Section, Institut für Uhr- ur Frühgeschichte und Archäologie des Mittelalters and Senckenberg Center for Human Evolution and Paleoecology, University of Tübingen, Tübingen, Germany

Abstract

Background: Discussion surrounding the settlement of the New World has recently gained momentum with advances in molecular biology, archaeology and bioanthropology. Recent evidence from these diverse fields is found to support different colonization scenarios. The currently available genetic evidence suggests a "single migration" model, in which both early and later Native American groups derive from one expansion event into the continent. In contrast, the pronounced anatomical differences between early and late Native American populations have led others to propose more complex scenarios, involving separate colonization events of the New World and a distinct origin for these groups.

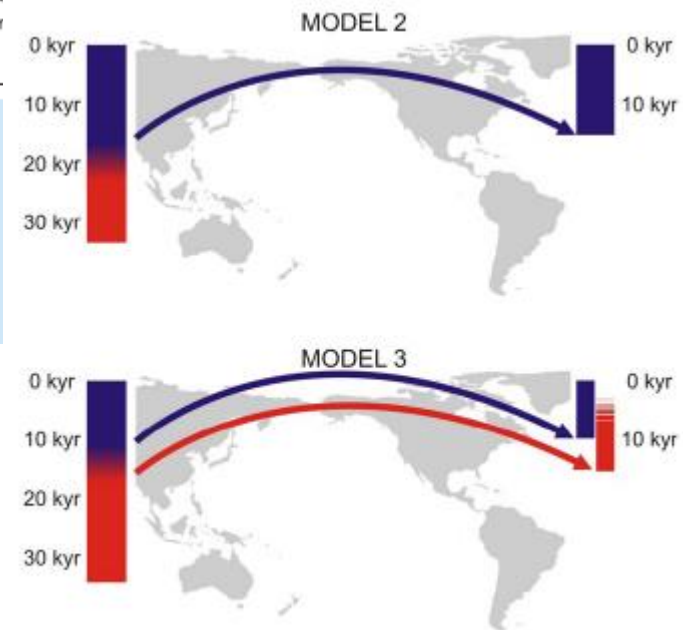



SPAnet

São Paulo Astronomy Network

São Paulo Astronomy Network

SPAnet

- An alliance of universities, institutions, and professionals, to boost the development of Astronomy and Astronomical Instrumentation research in the State of São Paulo.
 - Increase national and international visibility of São Paulo Astronomy,
 - Promote scientific education of our society and
 - Foster technological and economic contributions through a vigorous scientific instrumentation program.

<http://www.iag.usp.br/spanet/?q=en/home>



ASTRI MINI-ARRAY

Set of nine Cherenkov telescopes to capture gamma radiation of the universe, installed in the South Hemisphere.



LLAMA

12 meters diameter Radio telescope installed in the Argentine Andes to observe the millimeter and sub-millimeter wave Universe.



Giant Magellan Telescope

Super giant terrestrial telescope compound with 7 larger monolithic mirrors of the world, located in Chile.

SPANet Projects

- ASTRI MINI-ARRAY
- GMT - Giant Magellan Telescope
- LLAMA - Large Latin American Millimetric Array
 - Towards imaging the Event Horizon of a Black Hole (EHT)
 - Astrophysics with LLAMA through providing and integrating (band-9) receiver
- CTA - Cherenkov Telescope Array
- J-PAS – Javalambre – Physics of the Accelerating Universe
 - Stellar populations in the Milky Way
 - Project EMU: PAU – BRASIL
 - The 3-D Universe: Astrophysics with Large Galaxy Surveys
 - Study of star formation regions with J-PAS
- BINGO Telescope
- Gravitational Waves
 - Gravitational Wave Astronomy
 - Observatories For Gravitational Waves Astronomy
- High precision spectroscopy: impact in the study of planets, stars, the Galaxy and cosmology
- The study of the internal kinematics and of the stellar populations of nearby galaxies
- What Drives the Stellar Mass Growth of Early-Type Galaxies?
- CADA Project (Chemical Abundance Determinations in AGNs)
- HighPIDS - High Performance Intelligent Decision Systems for Solar Weather forecasting
- Constraints on the terminal ejection velocity fields of asteroid families
- SOUTH POL - Revealing the Polarized Southern Sky
- SPARC4 - Simultaneous Polarimeter And Rapid Camera in 4 bands
- Superdense Matter in the Universe

BIOEN has an impact in the International debate about bioenergy

<http://bioenfapesp.org/scopebioenergy/index.php>

SCOPE SYNTHESIS VOLUME

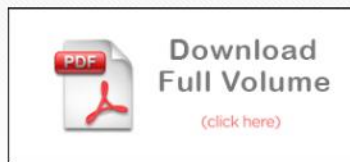

Chapters:  Download PDF

Read and search online

- Table of contents
- Executive Summary
- Chapter 1: Technical Summary
- Chapter 2: Bioenergy Numbers
- Chapter 7: The Much Needed Science: Filling the Gaps for Sustainable Bioenergy Expansion

Bioenergy & Sustainability: bridging the gaps

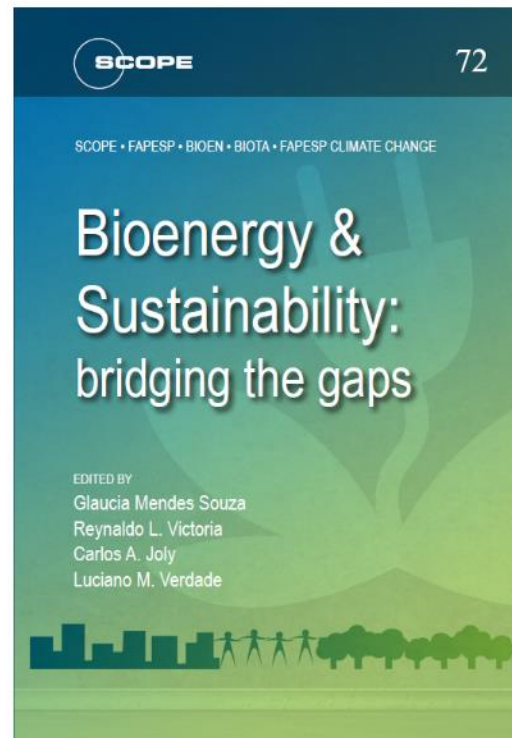

SCOPE Bioenergy & Sustainability is a collective effort with contributions from 137 researchers of 82 institutions in 24 countries.

The volume is the outcome of an assessment that included a meeting held at UNESCO, Paris, in December 2013. Fifty experts discussed bioenergy sustainability across its whole lifeline and crosscutting aspects including energy security, food security, environmental and climate security, sustainable development and innovation.

BIOTA: cascading effects in evolution **SCIENCE 2013**

31 MAY 2013 VOL 340 SCIENCE www.sciencemag.org

Functional Extinction of Birds Drives Rapid Evolutionary Changes in Seed Size

Mauro Galetti,^{1*} Roger Guevara,² Marina C. Côrtes,¹ Rodrigo Fadini,³ Sandro Von Matter,⁴ Abraão B. Leite,¹ Fábio Labecca,¹ Thiago Ribeiro,¹ Carolina S. Carvalho,⁵ Rosane G. Collevatti,⁵ Mathias M. Pires,⁶ Paulo R. Guimarães Jr.,⁶ Pedro H. Brancalion,⁷ Milton C. Ribeiro,¹ Pedro Jordano⁸

Local extinctions have cascading effects on ecosystem functions, yet little is known about the potential for the rapid evolutionary change of species in human-modified scenarios. We show that the functional extinction of large-gape seed dispersers in the Brazilian Atlantic forest is associated with the consistent reduction of the seed size of a keystone palm species. Among 22 palm populations, areas deprived of large avian frugivores for several decades present smaller seeds than nondefaunated forests, with negative consequences for palm regeneration. Coalescence and phenotypic selection models indicate that seed size reduction most likely occurred within the past 100 years, associated with human-driven fragmentation. The fast-paced defaunation of large vertebrates is most likely causing unprecedented changes in the evolutionary trajectories and community composition of tropical forests.



48% of Brazil's energy comes from renewable sources (2009)

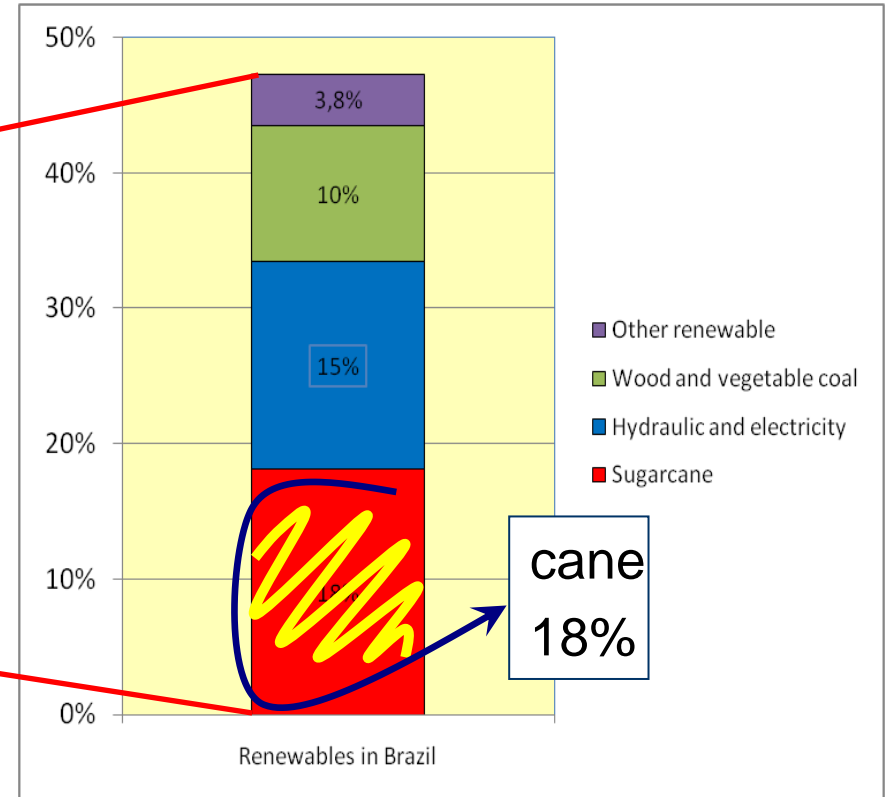
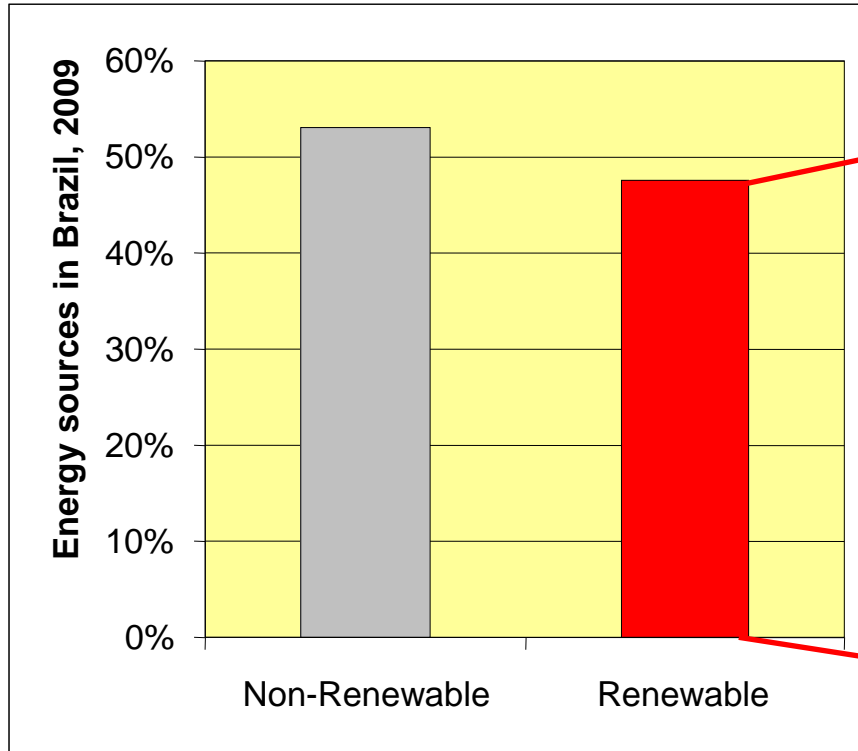

Renewables in Brazil: 48%; World: 13%; OECD: 7,2%

SP Environment Secretary bases Resolution on BIOTA research



SECRETARIA DE ESTADO DO MEIO AMBIENTE

GABINETE DO SECRETÁRIO

PUBLICADA EM 14/03/88 – SEÇÃO I – PÁG.36

RESOLUÇÃO SMA-15 DE 13 DE MARÇO DE 2008.

Dispõe sobre os critérios e parâmetros para concessão de autorização para supressão de vegetação nativa considerando as áreas prioritárias para incremento da conectividade.

O **SECRETÁRIO DE ESTADO DO MEIO AMBIENTE**, em cumprimento ao disposto nos artigos 23, VII, e 225, § 1º, I, da Constituição Federal, nos artigos 191 e 193 da Constituição do Estado, nos artigos 2º e 4º da Lei federal nº 6.938, de 31 de agosto de 1981, e nos artigos 2º, 4º e 7º da Lei estadual nº 9.509, de 20 de março de 1997, e

Considerando os resultados obtidos pela equipe de pesquisadores do Projeto Biota FAPESP e as informações presentes no mapa de "Áreas prioritárias para incremento da conectividade" e "Áreas prioritárias para criação de Unidades de Conservação" resultantes do Projeto Biota FAPESP;

- Plus two Governor's Edits
 - Decree 53.939, 06Jan09 – Legal Reserves
 - Decree 54.746, 04Sep09 – Conservation Units Cantareira

Political science



The City University of New York

Presidential Power, Legislative Organization, and Party Behavior in Brazil

Argelina Cheibub Figueiredo and Fernando Limongi

Presidential regimes are considered to be prone to produce institutional deadlocks. In the generally shared view, influenced by the work of Juan Linz, presidentialism lacks a built-in mechanism to induce cooperation between the executive and legislative branches of the government.¹ Representatives and the president have different constituencies, and their mandates are independent and fixed. Hence the chances that the legislative and the executive powers will have the same agenda are small.

Greek philosophy

Philosophia Antiqua

A Series of Studies on Ancient Philosophy

Previous Editors

J.H. Waszink†
W.J. Verdenius†
J.C.M. van Winden

Edited by

K.A. Algra
F.A.J. de Haas
J. Mansfeld
D.T. Runia

VOLUME 106

AKRASIA AND THE METHOD OF ETHICS*

MARCO ZINGANO

The discussion of the phenomenon of *akrasia* carried on by Aristotle displays, as one knows, several difficulties, which have caused reiterated debates amongst contemporary interpreters. These controversies are not just concerned to side issues, but they touch, as it turns out, central issues. In this essay I shall focus my attention on an issue that is mainly a methodological one. My main interest is to understand the role that the Socratic thesis plays in Aristotle's discussion of the topic. It still is an issue of debate what Aristotle's position regarding the Socratic doctrine exactly is: does he simply expose it, or does he adopt it—and, in the latter case, up to what extent? There is place, however, for a more initial, and stronger, astonishment: why does Aristotle busy himself with it at all? After all, Socrates denied altogether the possibility of the weakness of will, and Aristotle not only wants to tackle this problem in a dialectical context in which *akrasia* is, on the contrary, taken as existent (so that the Socratic thesis is seen as something clearly opposed to the

FAPESP-U.S. research collaboration

- NSF
 - Dimensions of Biodiversity
 - PIRE
 - CNIC
- DoE
 - Amazon research
 - Clean Energy
 - High Energy Physics - neutrinos
- NIH – announced Feb, 2016
 - 19 institutes
 - Joint review
- Universities
 - Michigan, MIT, Ohio, USC, UC Davis, U. Florida, NCSU, UNC-Charlotte, Scripps, Emory,....

Research collaboration Ohio State U.-São Paulo

Histórico do fomento, por ano de início

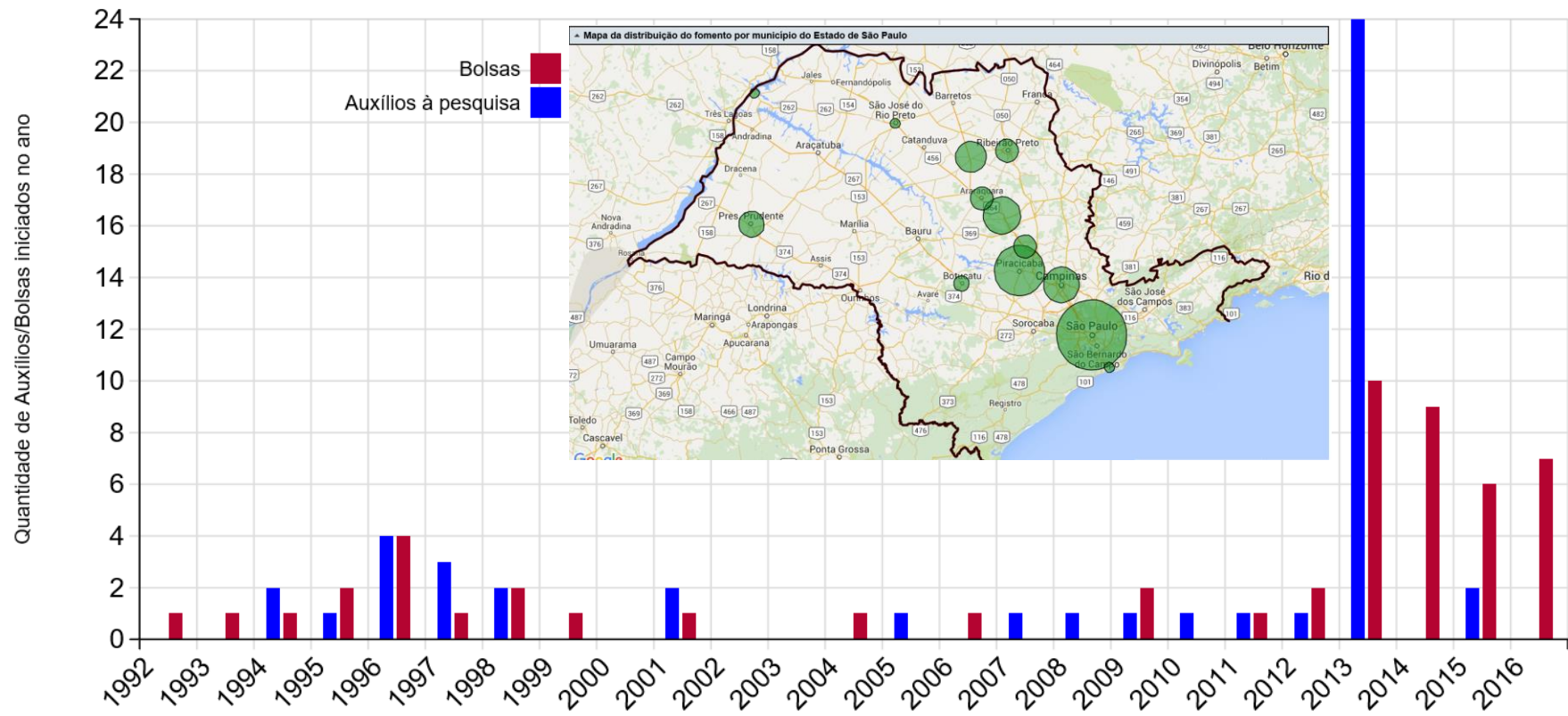

Co-authorships: Ohio State U. and São Paulo

Citation Report: 1761

(from Web of Science Core Collection)

You searched for: Ad=(brasil or brazil) AND ad= ("sao paulo" or sp or "s paulo" or "san paulo") ...[More](#)

This report reflects citations to source items indexed within Web of Science Core Collection. Perform a Cited Reference Search to include citations to ite

Published Items in Each Year

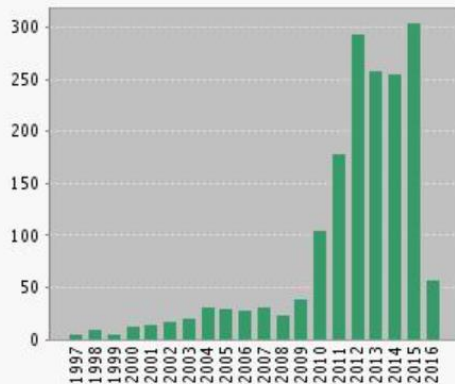

The latest 20 years are displayed.
[View a graph with all years.](#)

Citations in Each Year

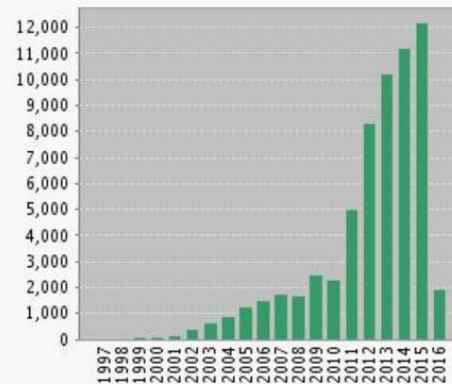

The latest 20 years are displayed.
[View a graph with all years.](#)

- PHYSICS (1,270)
- ASTRONOMY ASTROPHYSICS (516)
- INSTRUMENTS INSTRUMENTATION (62)
- AGRICULTURE (48)
- SCIENCE TECHNOLOGY OTHER TOPICS (28)
- ONCOLOGY (27)
- EVOLUTIONARY BIOLOGY (23)
- BIOCHEMISTRY MOLECULAR BIOLOGY (23)
- ANTHROPOLOGY (20)
- PLANT SCIENCES (18)
- NUCLEAR SCIENCE TECHNOLOGY (18)
- ENGINEERING (17)
- SURGERY (16)
- VETERINARY SCIENCES (15)
- METALLURGY METALLURGICAL ENGINEERING (15)
- CHEMISTRY (14)
- CARDIOVASCULAR SYSTEM CARDIOLOGY (14)
- SPECTROSCOPY (13)
- FOOD SCIENCE TECHNOLOGY (13)
- BIOTECHNOLOGY APPLIED MICROBIOLOGY (13)
- NEUROSCIENCES NEUROLOGY (12)
- MATERIALS SCIENCE (12)
- ENTOMOLOGY (12)

Research collaboration U. Michigan-São Paulo

Histórico do fomento, por ano de início

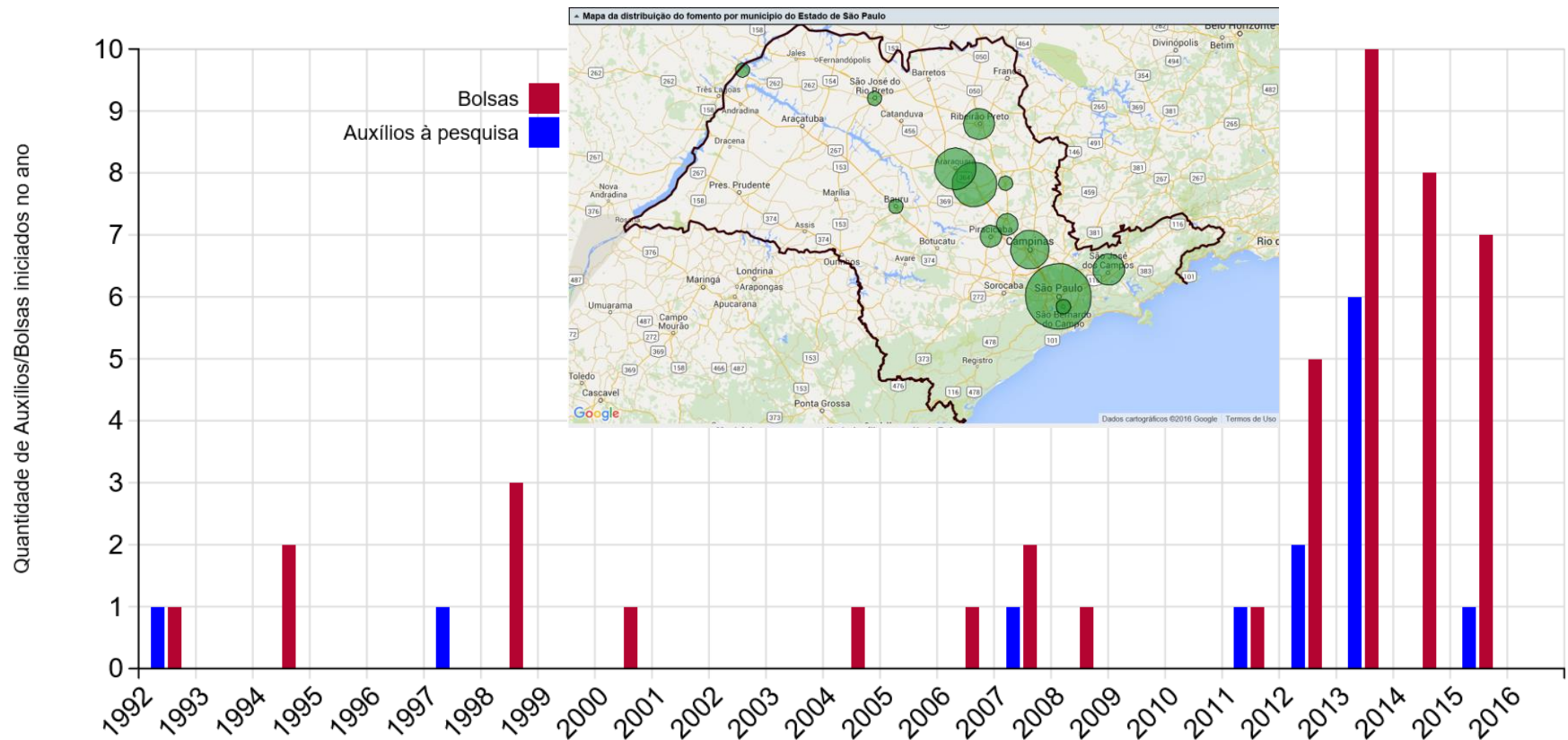

Co-authorships: U. Michigan and São Paulo

Citation Report: 1507

(from Web of Science Core Collection)

You searched for: Ad=(brasil or brazil) AND ad= ("sao paulo" or sp or "s paulo" or "san paulo") ...[More](#)

This report reflects citations to source items indexed within Web of Science Core Collection. Perform a Cited Reference Search to include citations to items r

Published Items in Each Year

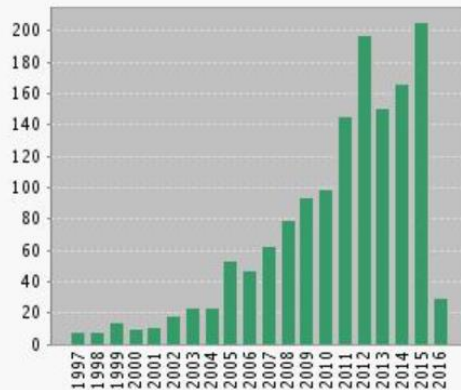

The latest 20 years are displayed.
[View a graph with all years.](#)

Citations in Each Year

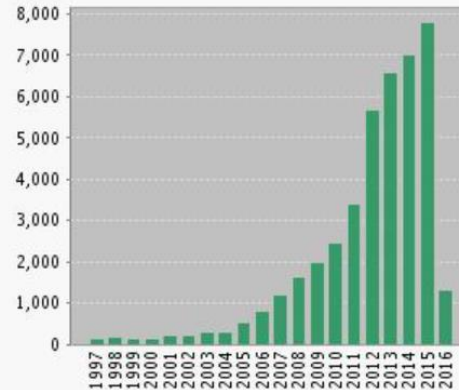

The latest 20 years are displayed.
[View a graph with all years.](#)

- PHYSICS (821)
- ASTRONOMY ASTROPHYSICS (386)
- DENTISTRY ORAL SURGERY MEDICINE (89)
- CARDIOVASCULAR SYSTEM CARDIOLOGY (49)
- IMMUNOLOGY (41)
- SURGERY (40)
- BIOCHEMISTRY MOLECULAR BIOLOGY (36)
- PUBLIC ENVIRONMENTAL OCCUPATIONAL HEALTH (33)
- CELL BIOLOGY (32)
- OBSTETRICS GYNECOLOGY (31)
- SCIENCE TECHNOLOGY OTHER TOPICS (29)
- GENETICS HEREDITY (28)
- REPRODUCTIVE BIOLOGY (27)
- ONCOLOGY (27)
- TRANSPLANTATION (24)
- ENDOCRINOLOGY METABOLISM (24)
- ENVIRONMENTAL SCIENCES ECOLOGY (23)
- OPHTHALMOLOGY (21)
- PLANT SCIENCES (19)
- ENGINEERING (19)
- CHEMISTRY (19)
- HEMATOLOGY (17)
- GENERAL INTERNAL MEDICINE (17)
- MATHEMATICS (15)



Biodiversity Research: BIOTA Research Program

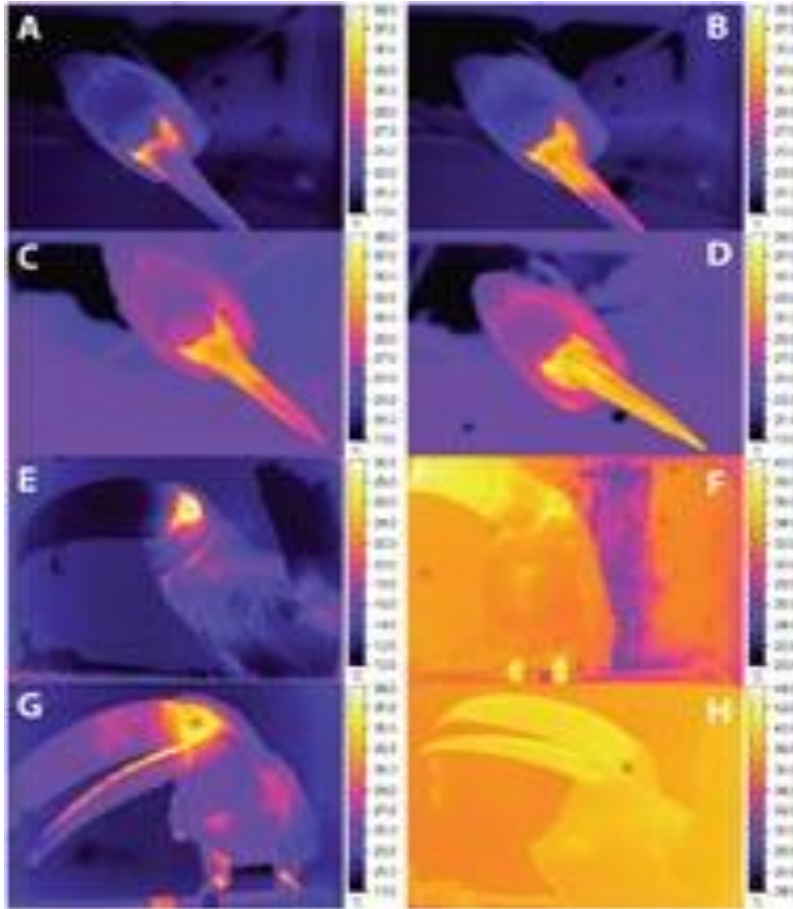

Heat Exchange from the Toucan Bill Reveals a Controllable Vascular Thermal Radiator
 Glenn J. Tattersall, *et al.*
Science 325, 468 (2009);
 DOI: 10.1126/science.1175553

REPORTS

Heat Exchange from the Toucan Bill Reveals a Controllable Vascular Thermal Radiator

Glenn J. Tattersall,^{1,3} Denis V. Andrade,^{2,3} Augusto S. Abe^{2,3}

The toco toucan (*Ramphastos toco*), the largest member of the toucan family, possesses the largest beak relative to body size of all birds. This exaggerated feature has received various interpretations, from serving as a sexual ornament to being a refined adaptation for feeding. However, it is also a significant surface area for heat exchange. Here we show the remarkable capacity of the toco toucan to regulate heat distribution by modifying blood flow, using the bill as a transient thermal radiator. Our results indicate that the toucan's bill is, relative to its size, one of the largest thermal windows in the animal kingdom, rivaling elephants' ears in its ability to radiate body heat.

% dos recursos para P&D obtidos de empresas: USP, UNESP, Unicamp

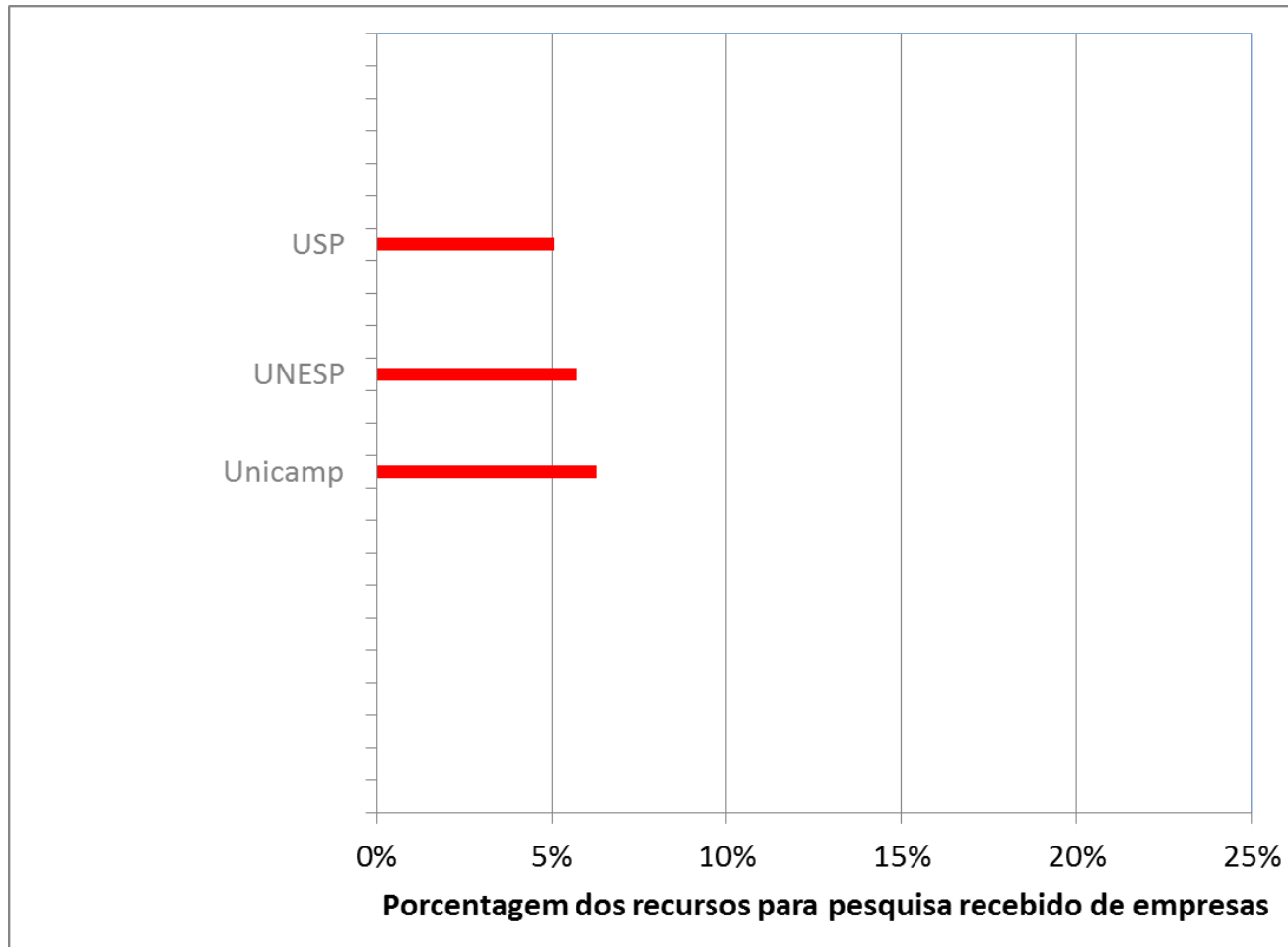

% dos recursos para P&D obtidos de empresas: USP, UNESP, Unicamp e EUA

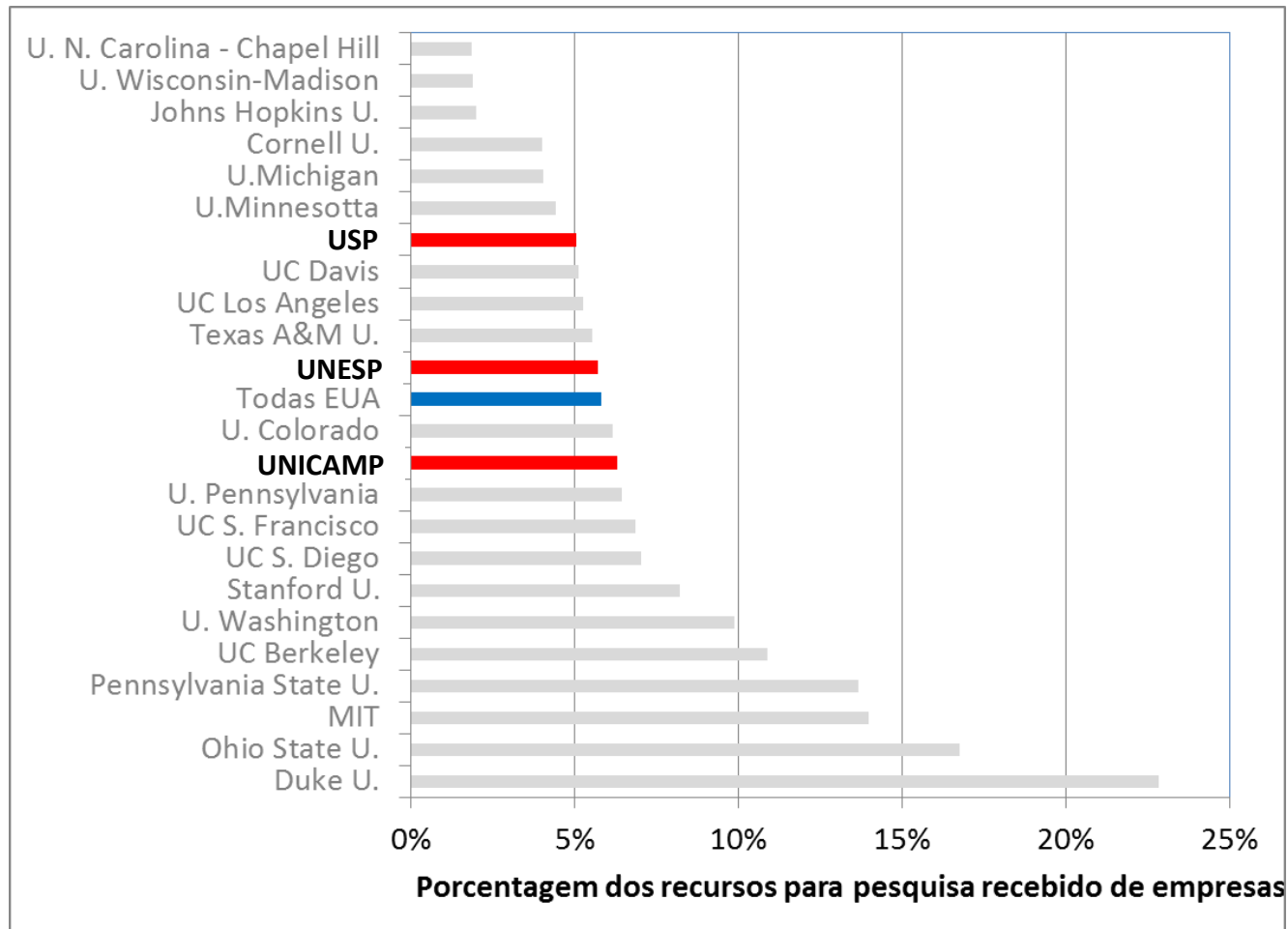

Target gene to treat Duchenne muscular dystrophy (DMD)



Jagged 1 Rescues The Duchenne Muscular Dystrophy Phenotype.

Erica L. M. Vieira, Ingegerd Elvers, Matthew S. Alexander, Yuri B. Moreira, Alal Eran, Juliana Gomes, Jamie L Marshall, Elinor K. Karlsson, Sergio Verjovski-Almeida, Kerstin Lindblad-Toh, Louis M Kunkel and Mayana Zatz

Cell

Published November 19th, 2015

Target gene identified for therapies to combat muscular dystrophy

November 12, 2015



By **Karina Toledo** | Agência FAPESP – Researchers at the University of São Paulo's Bioscience Institute (IB-USP) in Brazil have shown that a gene called Jagged1, or JAG1 for short, could be a target for the development of new approaches to treat Duchenne muscular dystrophy (DMD), a genetic disorder characterized by progressive muscle degeneration.

The research was carried out at the [Human Genome and Stem-Cell Research Center](#) (HUG-CELL), one of the [Research, Innovation and Dissemination Centers](#) (RIDCs) supported by FAPESP. The findings [were published](#) in the journal *Cell*.



Study published in *Cell* by researchers from Brazil and the United States suggests inducing overexpression of the Jagged1 gene can prevent the development of degenerative disease (photo: Cecilia Bastos / USP)

Personalized medicine

www.impactjournals.com/oncotarget/

Oncotarget, Advance Publications 2015

The use of personalized biomarkers and liquid biopsies to monitor treatment response and disease recurrence in locally advanced rectal cancer after neoadjuvant chemoradiation

Paola Carpinetti^{1,2,3}, Elisa Donnard^{1,2,3}, Fabiana Bettoni², Paula Asprino², Fernanda Koyama¹, Andrei Rozanski², Jorge Sabbaga⁴, Angelita Habr-Gama^{5,6}, Raphael B. Parmigiani², Pedro A.F. Galante², Rodrigo O. Perez^{1,5,6}, Anamaria A. Camargo^{1,2}

¹Ludwig Institute for Cancer Research, São Paulo, SP, Brazil

²Centro de Oncologia Molecular Hospital Sírio Libanês, São Paulo, Brazil

³Programa de Pós Graduação em Bioquímica, Instituto de Química, Universidade de São Paulo, SP, Brazil

⁴Centro de Oncologia Clínica, Hospital Sírio Libanês, São Paulo, SP, Brazil

⁵Angelita & Joaquim Gama Institute, São Paulo, SP, Brazil

⁶University of São Paulo, School of Medicine, São Paulo, SP, Brazil

Correspondence to:

Anamaria A. Camargo, **e-mail:** aacamargo@mochsl.org.br

Better microorganisms for biofuels production



Genome structure of a *Saccharomyces cerevisiae* strain widely used in bioethanol production

Juan Lucas Argueso,^{1,9,10} Marcelo F. Carazzolle,^{3,9} Piotr A. Mieczkowski,^{6,9} Fabiana M. Duarte,³ Osmar V.C. Netto,³ Silvia K. Missawa,³ Felipe Galzerani,³ Gustavo G.L. Costa,³ Ramon O. Vidal,³ Melline F. Noronha,³ Margaret Dominska,¹ Maria G.S. Andrietta,⁴ Sílvia R. Andrietta,⁴ Anderson F. Cunha,⁵ Luiz H. Gomes,⁷ Flavio C.A. Tavares,⁷ André R. Alcarde,⁸ Fred S. Dietrich,^{1,2} John H. McCusker,¹ Thomas D. Petes,¹ and Gonçalo A.G. Pereira^{3,10}

Pesquisa FAPESP – five students hired by Braskem

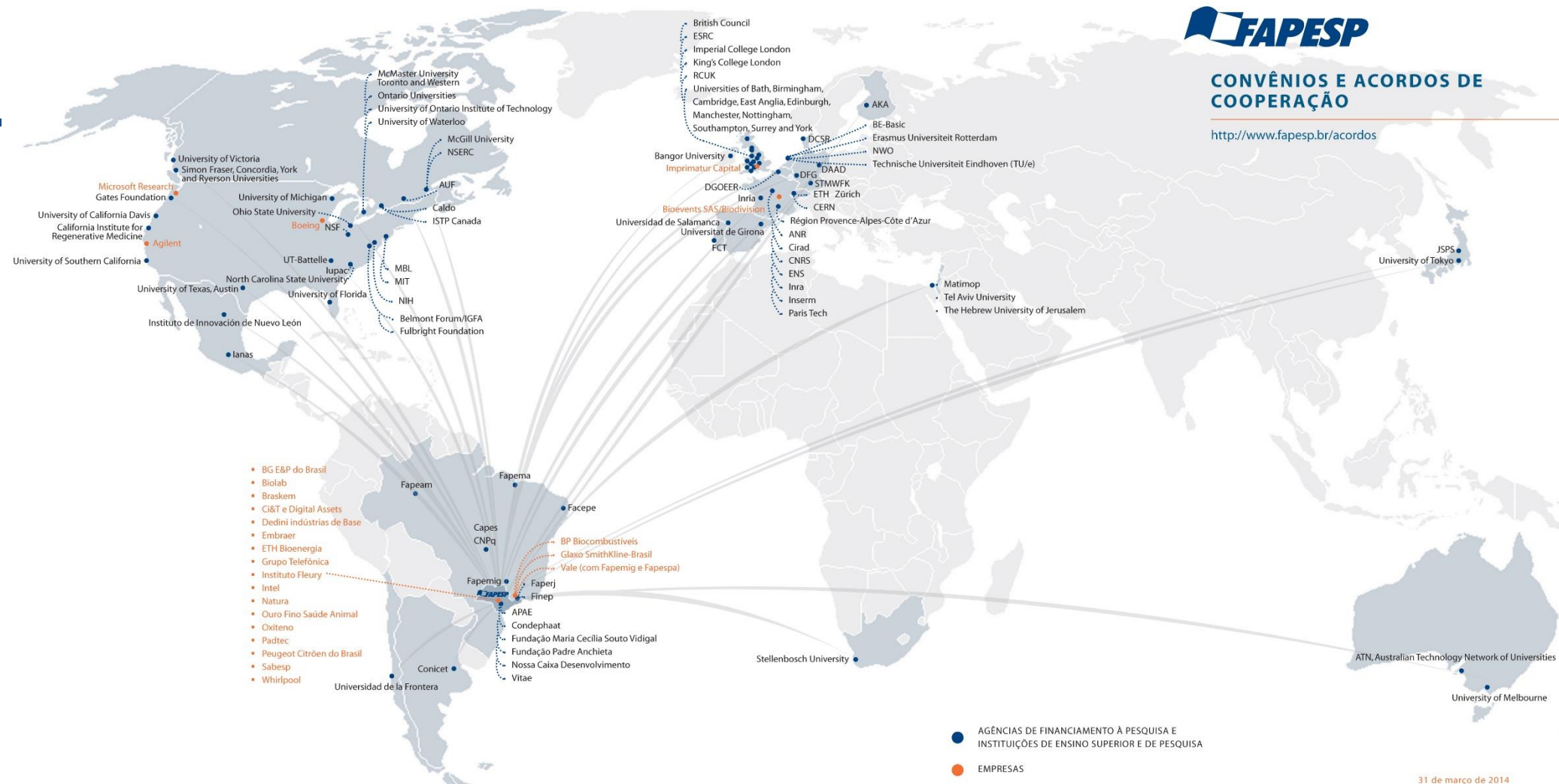

31 de março de 2014

Brasil: R&D Expenditures, 2012, by source

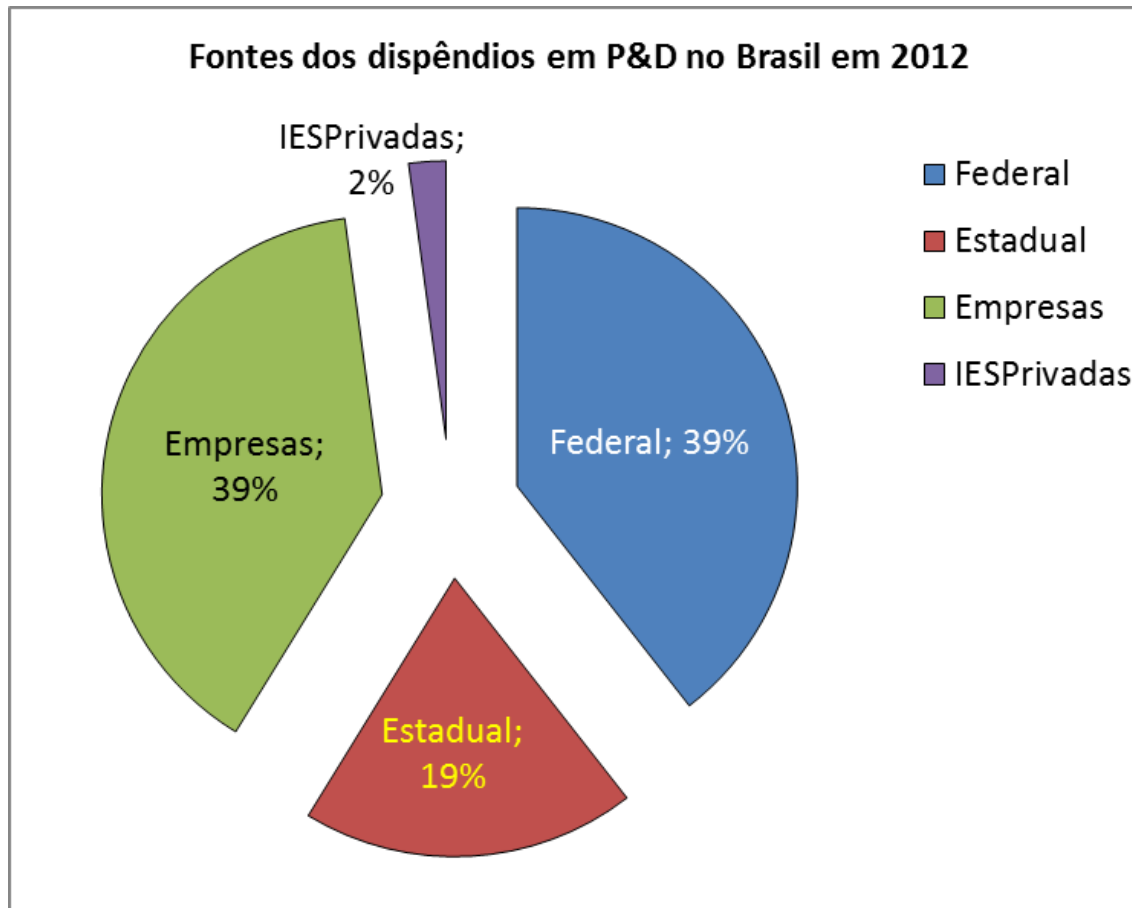

- R&D intensity – 1,15% of GDP
- Gov. expenditure
 - States 33%
 - Federal 67%

Vaccines research

The Telegraph

Home News World Sport Finance Comment Culture Travel Life Women Fashion
USA Asia China Europe Middle East Anstralasia Africa Nelson Mandela South Amer

HOME » NEWS » WORLD NEWS » SOUTH AMERICA » BRAZIL

Brazilian scientists to test AIDS 'vaccine' on monkeys

Brazilian scientists have developed an HIV vaccine and plan to begin testing on monkeys later this year, a sponsor institution has said.



Scientists plan to test the 'vaccine' on a colony of rhesus monkeys provided by Sao Paulo state's BRASILIAN UNIVERSITY FEDERAL institute Photo: Alamy

AIDS:

28 November 2006 - Volume 20 - Issue 18 - p 2263–2273

doi: 10.1097/01.aids.0000253353.48331.5f

Basic Science

Identification of novel consensus CD4 T-cell epitopes from clade B HIV-1 whole genome that are frequently recognized by HIV-1 infected patients

Fonseca, Simone G^{a,b,c}; Coutinho-Silva, Adriana^{a,b,c}; Fonseca, Luiz Augusto M^{b,c}; Segurado, Aluisio C^{c,d}; Moraes, Sandra L^{a,c,e}; Rodrigues, Hécio^b; Hammer, Juergen^f; Kallás, Esper G^{c,g}; Sidney, John^h; Sette, Alessandro^h; Kalil, Jorge^{a,b,c}; Cunha-Neto, Edecio^{a,b,c}

OPEN ACCESS Freely available online

PLoS one

A Vaccine Encoding Conserved Promiscuous HIV CD4 Epitopes Induces Broad T Cell Responses in Mice Transgenic to Multiple Common HLA Class II Molecules

Susan Pereira Ribeiro^{1,3*}, Daniela Santoro Rosa^{1,3*}, Simone Gonçalves Fonseca^{1,2}, Eliane Conti Mairena^{2,3}, Edilberto Postól^{2,3}, Sergio Costa Oliveira⁴, Luiza Guilherme^{2,3}, Jorge Kalil^{1,2,3}, Edecio Cunha-Neto^{1,2,3*}

1 Laboratory of Clinical Immunology and Allergy-LIM60, Division of Clinical Immunology and Allergy, Department of Medicine, University of São Paulo School of Medicine, São Paulo, Brazil, **2** Heart Institute (InCor), University of São Paulo School of Medicine, São Paulo, Brazil, **3** Institute for Investigation in Immunology-INCT, São Paulo, Brazil, **4** Department of Biochemistry and Immunology, Federal University of Minas Gerais, Belo Horizonte, Brazil

Summary

- State-level initiatives in Brazil
 - Why they matter
 - Results and characteristics
 - Multiplicative effects
- Conclusion

Flow of ideas and personnel: optical communications in Campinas

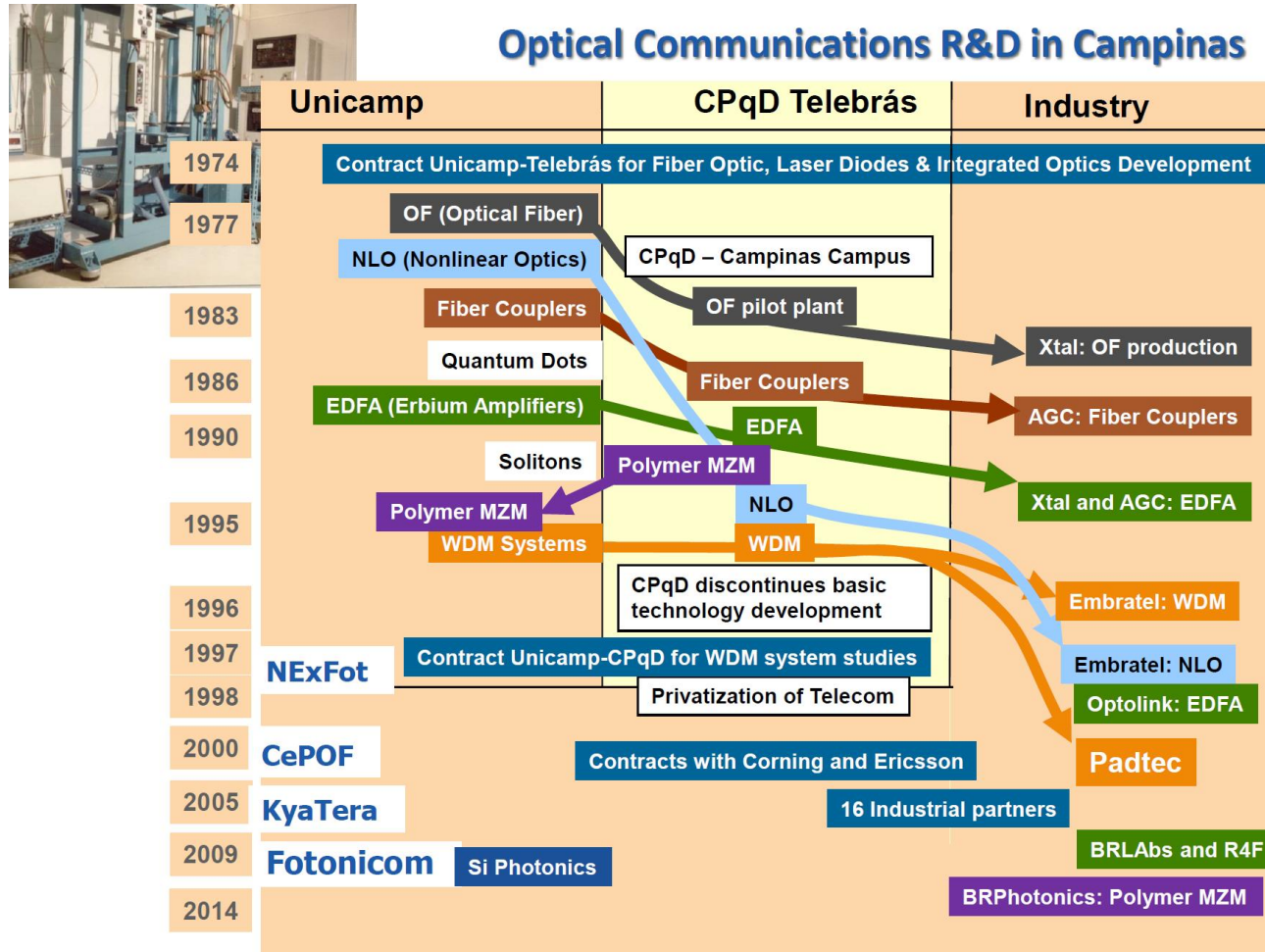

The State of São Paulo has a distinct funding policy

- Funding for the state universities is a fixed percentage (9.57%) of the sales tax
- Funding for FAPESP is 1% of total state fiscal revenues
 - Stability and Autonomy
- Effects
 - 25% of the country's scientists create 44% of the scientific articles and supervise 40% of the doctoral thesis concluded each year
 - Intense university-industry research interaction

State initiatives inspired by FAPESP

- FAPESP started in 1962
- Later served as model for other states
- Now 25 of 26 states (and a Federal District) have a state agency to fund research (FAP)
- Considering federal and state funding agencies, state agencies contribute 25-30% of total funding from agencies in the country

University – Industry joint research

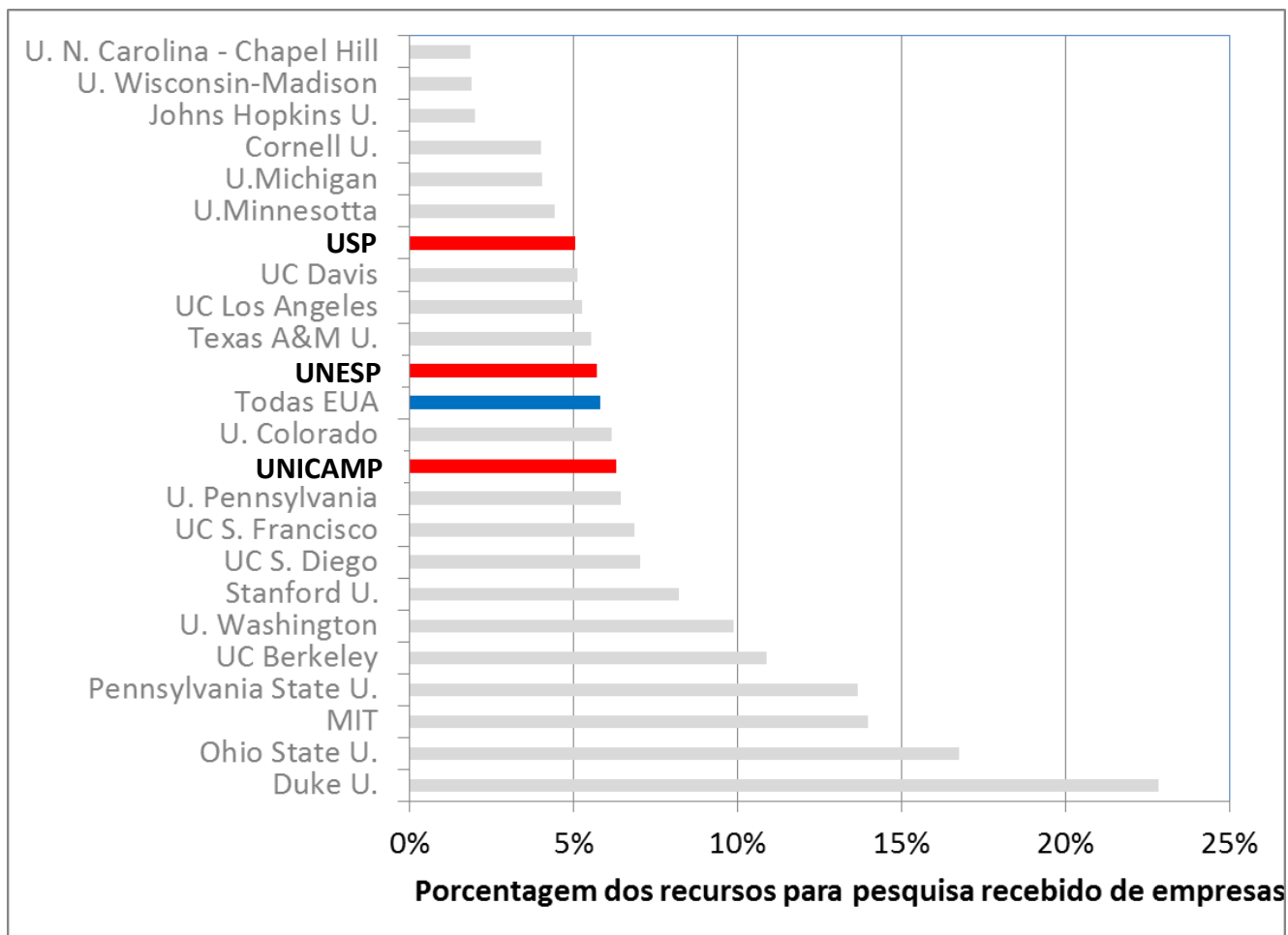

State level support for R&D in Brazil, 2010

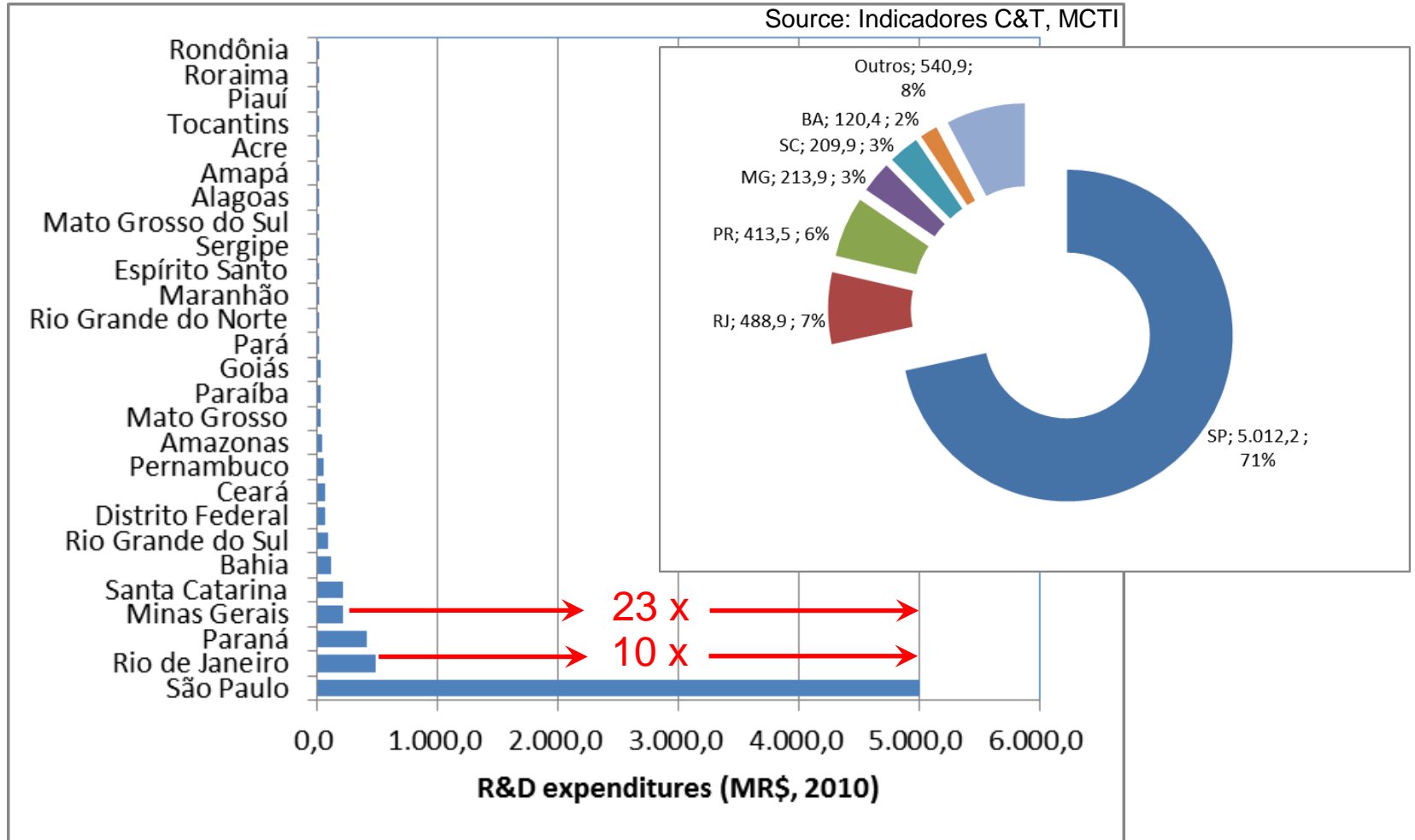

Challenges for the national higher education system

- Quality
 - Quantity and quality of high school education
 - Qualification of faculty
 - Federal universities: 60% of faculty with a PhD degree
- Lack of autonomy
 - Restriction to the use of funds, hiring, career,...
- Heterogeneity/Concentration

Stagnated quantity of high school graduates

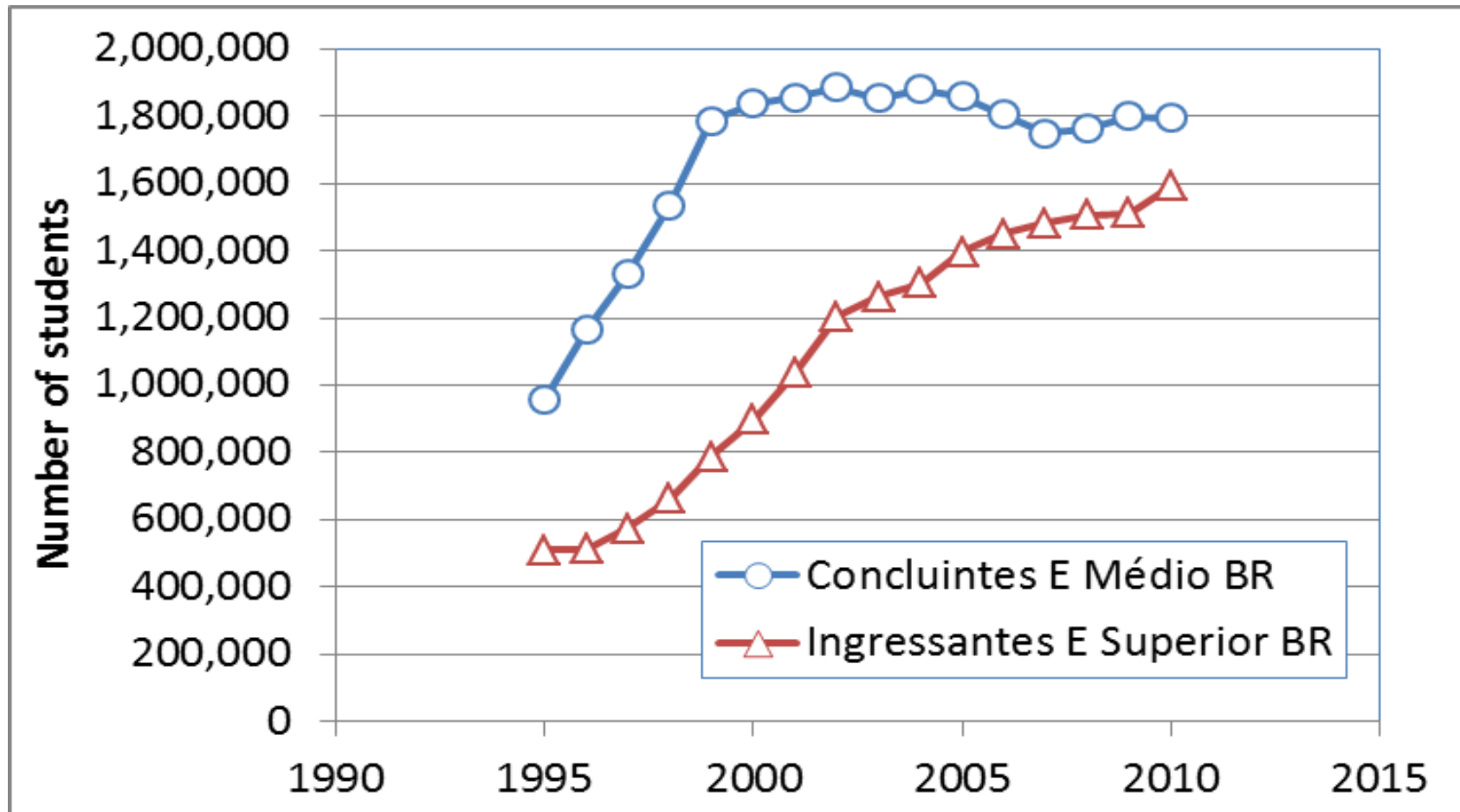

Challenges for industrial R&D and innovation

- Unbalanced drivers
 - Strong governmental incentives
 - Strong government-created obstacles
 - Unstable policies, high labour costs, high costs for capital, cumbersome tax system, legal uncertainties
 - Protectionist policies and small international exposure
- R&D is mostly adaptative
 - Weak IP creation

Patents granted by USPTO

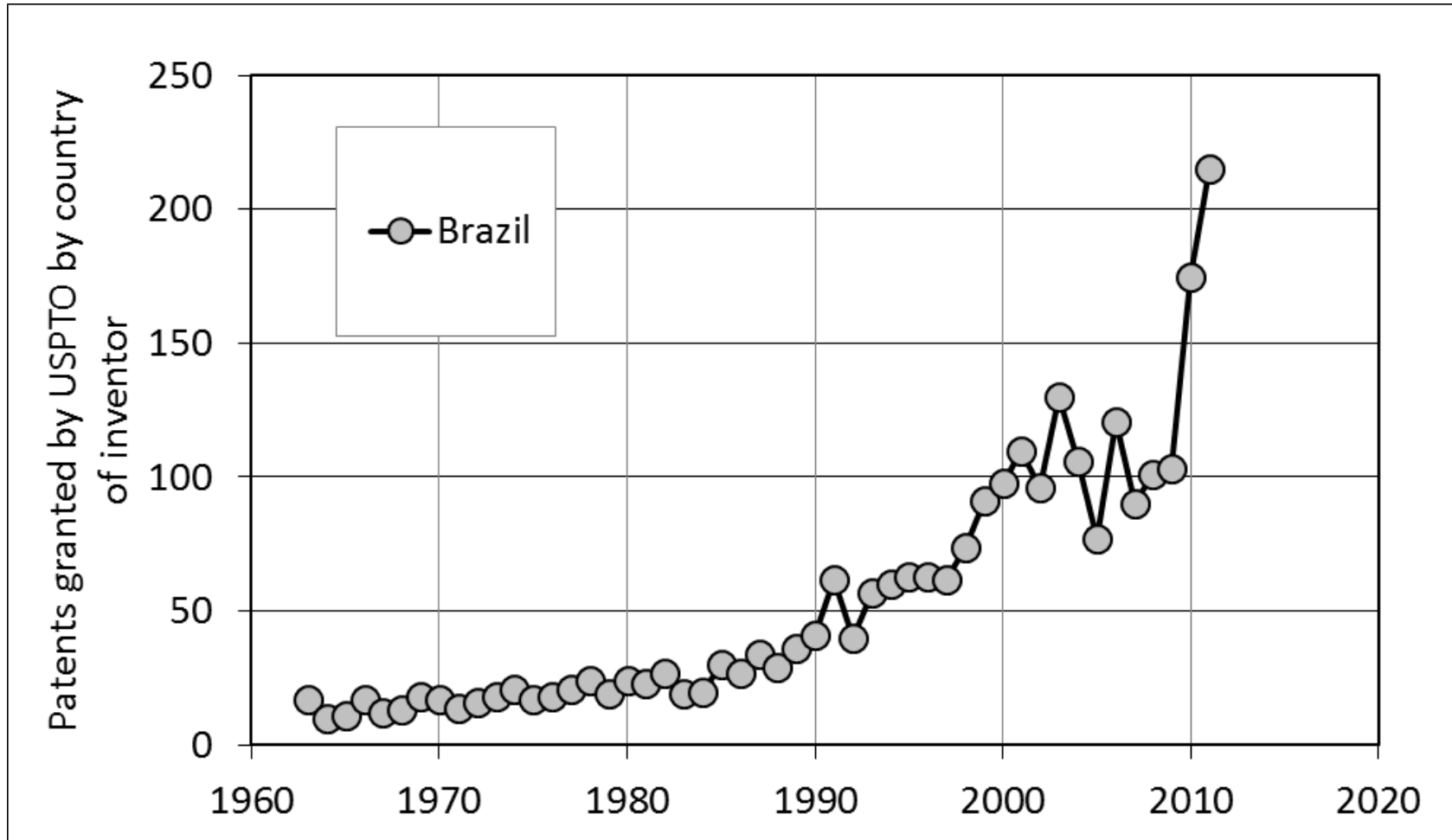

Patents granted by USPTO

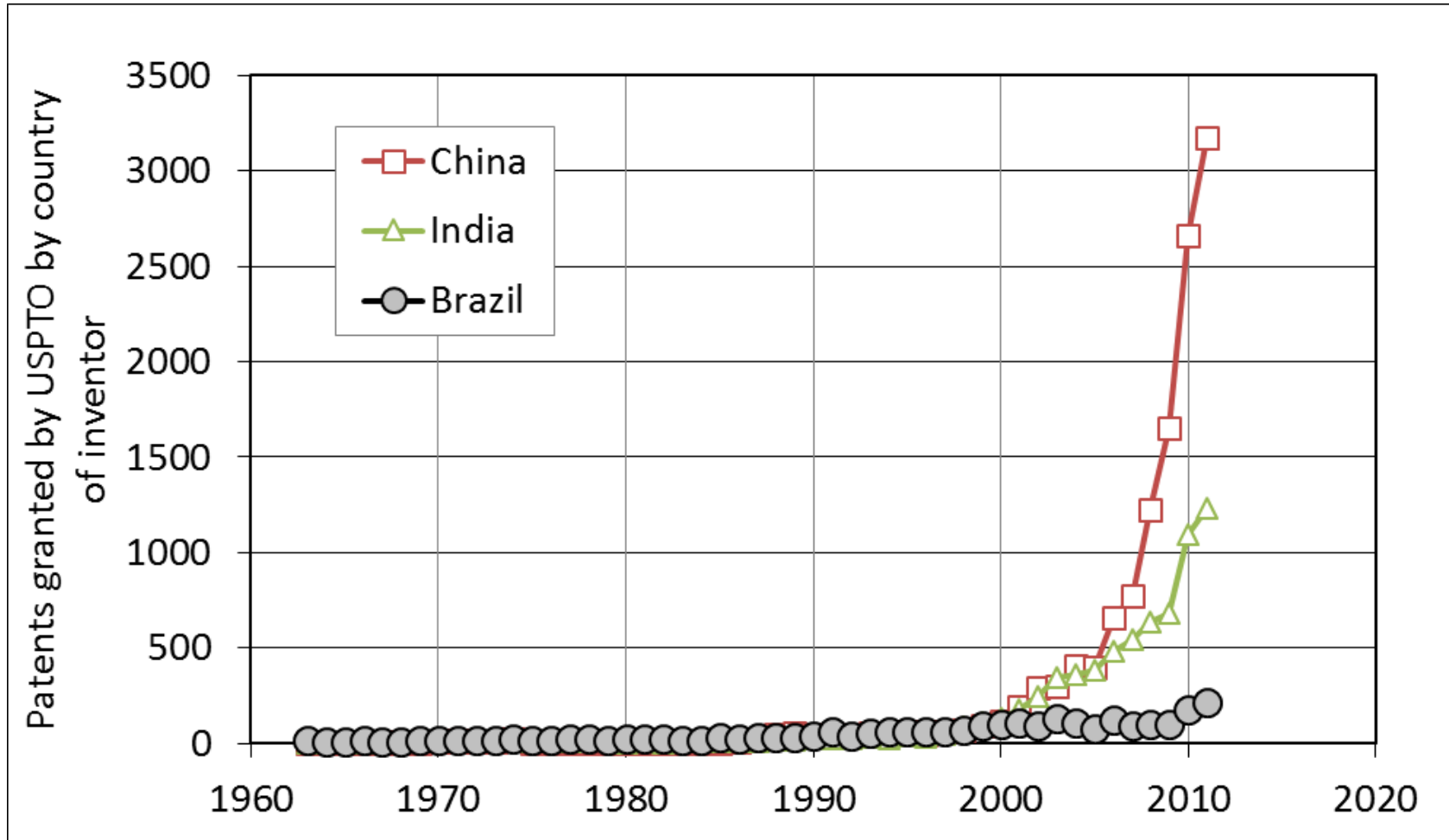

R&D in Brazil

- A strong academic base
 - 15,000 Doctorates granted yearly
 - 40,000 scientific papers published yearly
 - Challenges: impact, reduce geographic concentration in SE, weak international cooperation
- Growing intensity of industry R&D
 - Brazilian companies:
 - Petrobrás: 11st in R&D in Oil Sector
 - Embraer: 17th in R&D in Aerospace
 - Embrapa and state institutes: agrobusiness driver (Brazil 1st in soy productivity, 1st in meat exports, ..)
 - Challenges: too incremental, weak international focus, only 30% of scientists work in industry, weak IP creation

Mitigating wedges: Carbon emissions reduction in NPS

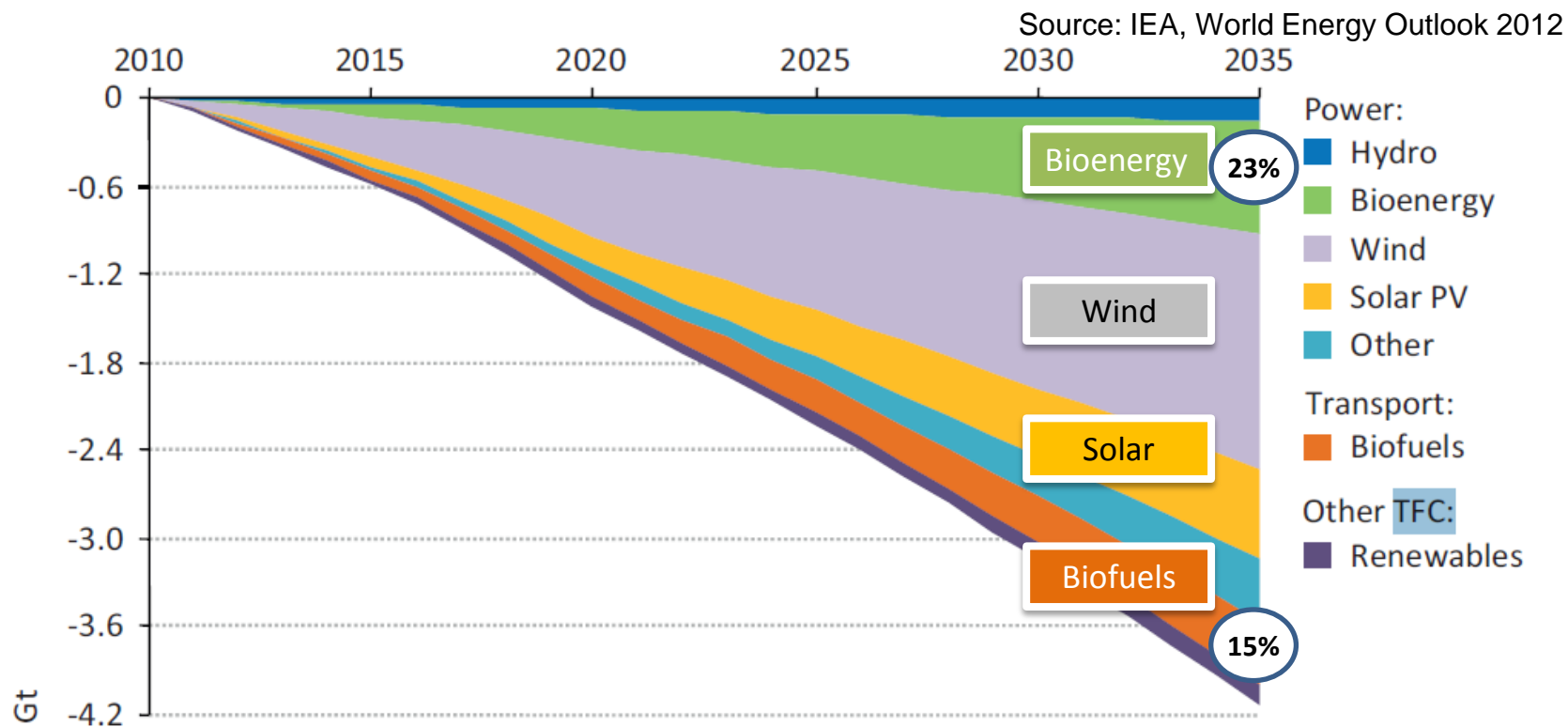

* The emissions savings compared with the emissions that would have been generated for the projected level of electricity generation in the New Policies Scenario were there no change in the mix of fuels and technologies and no change in the efficiency of thermal generating plants after 2010.

1980-2013: change in energy sources in the State of São Paulo, Brazil

State of São Paulo

- 42 million people
- 32% of Brazil's GNP
- 55% of Brazilian ethanol production

1980 – 2013

- Oil down from 62% to 38%
- Cane up from 14% to 32%

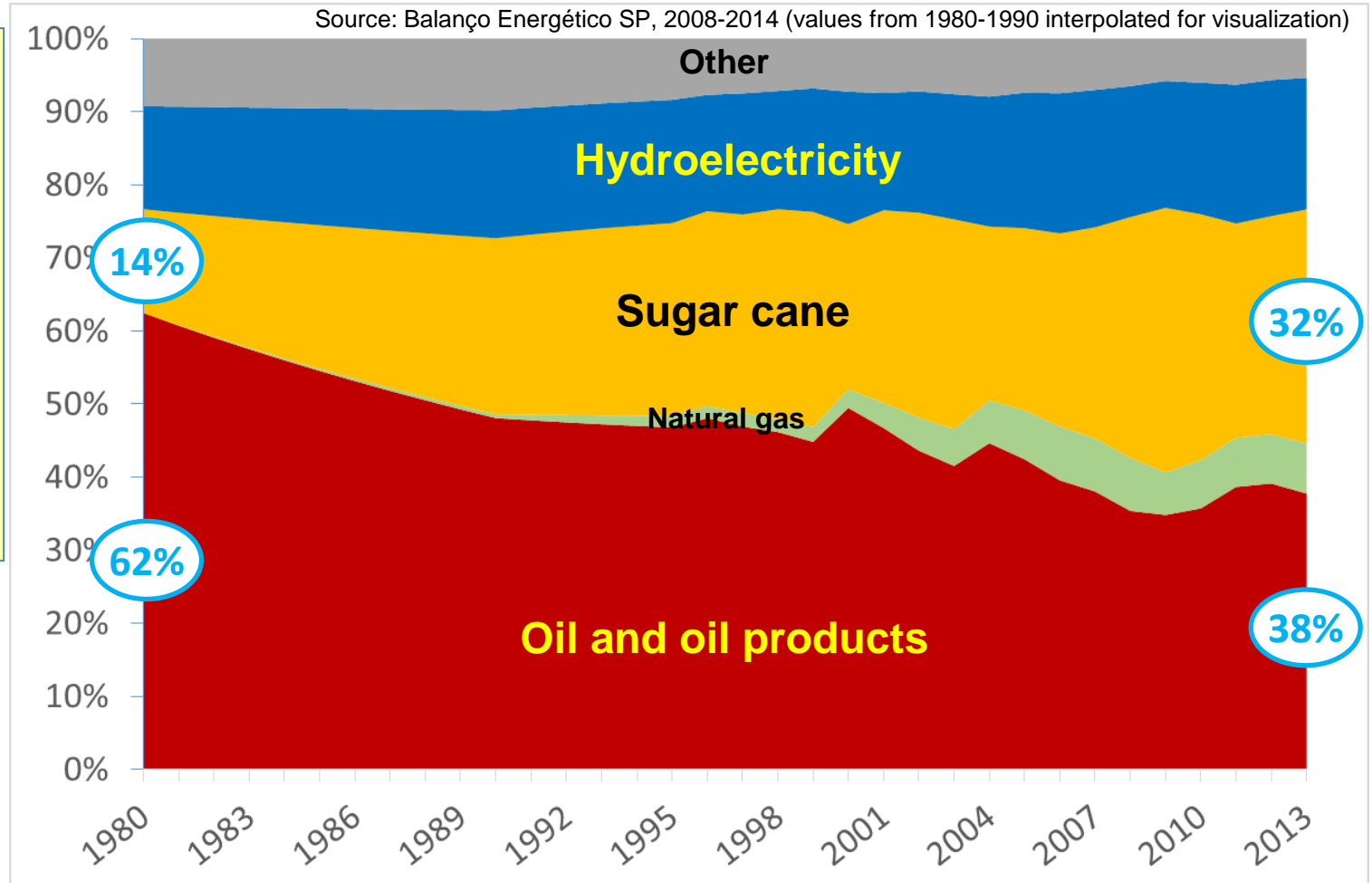

Vehicles per population

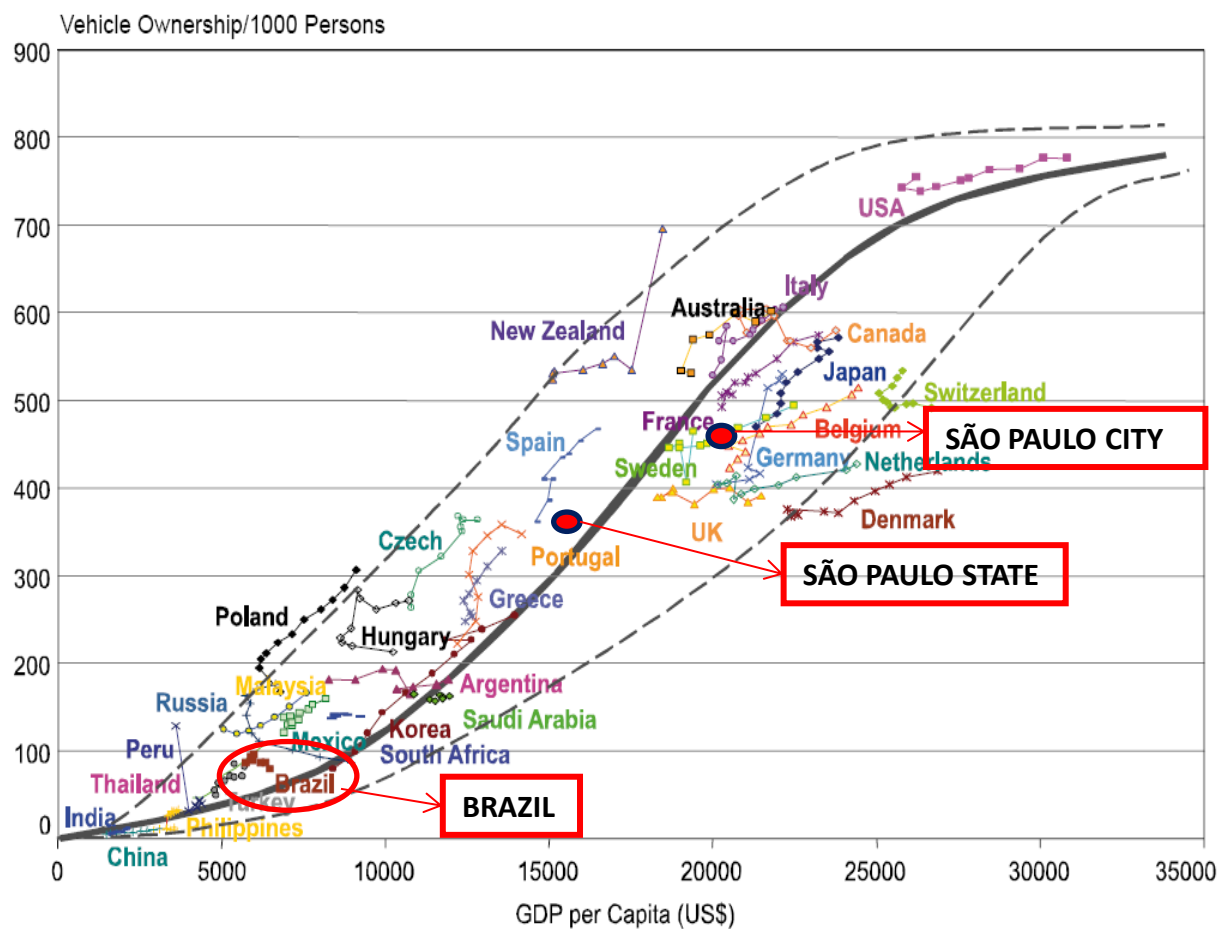

São Paulo: Land Use Change, 1970-2006

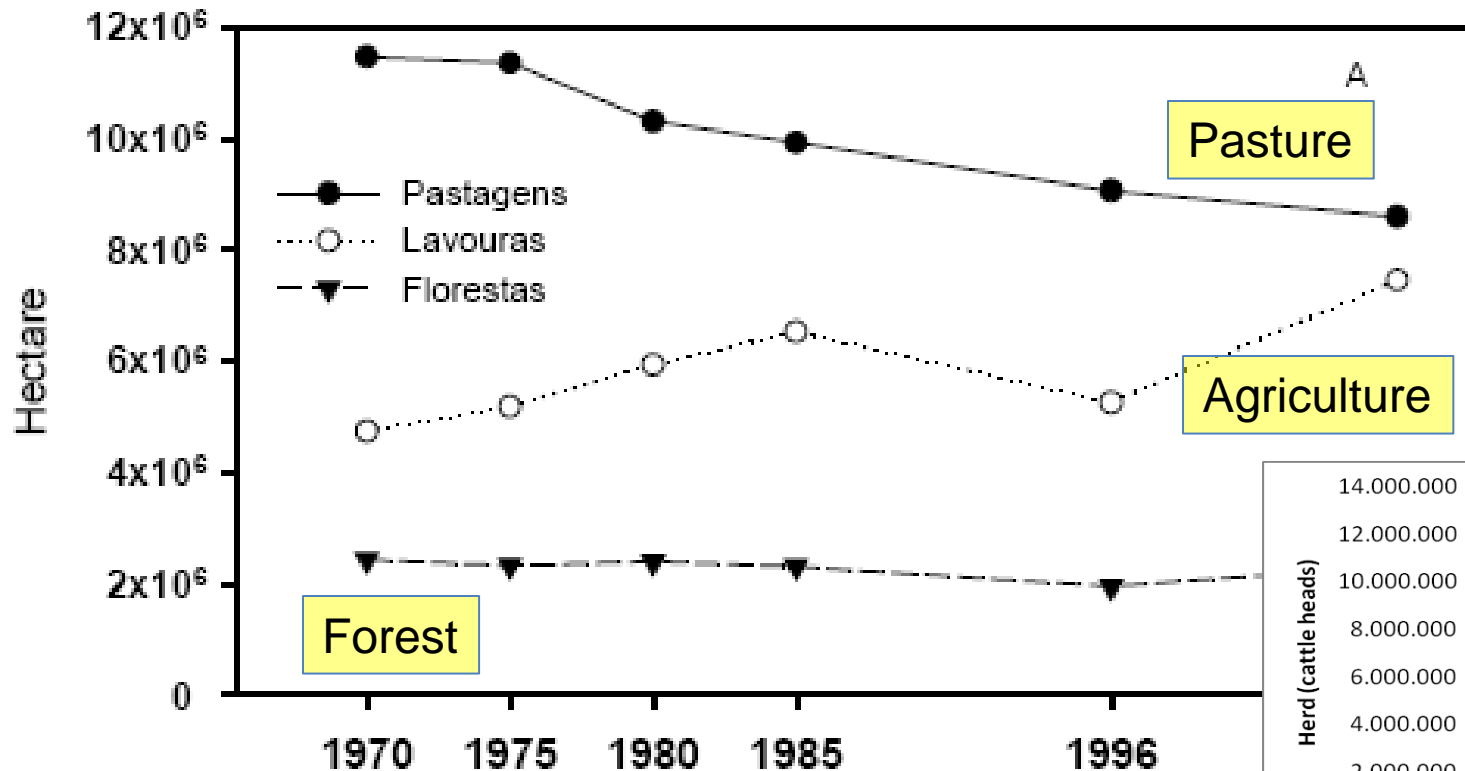

Sugarcane x Pasture: fixation of 0,5 Mg C/ha.yr

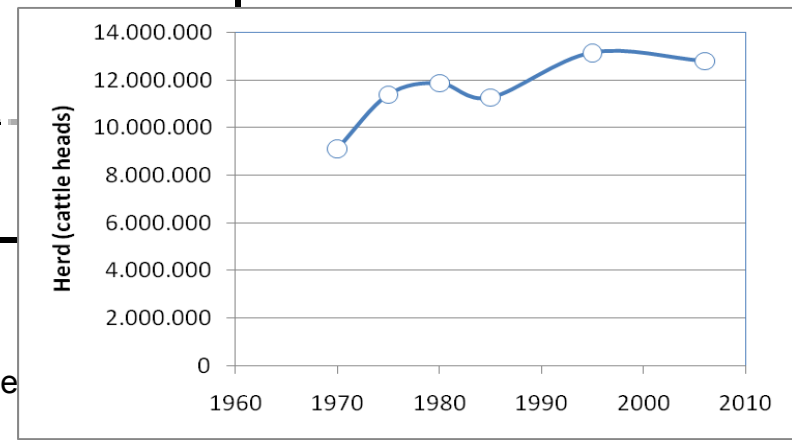

Source: Boddey, R.M., "GHG Emission Mitigation Through Ethanol from Sugarcane"

Center for Metropolitan Studies: *public policy research*

Quality of public education

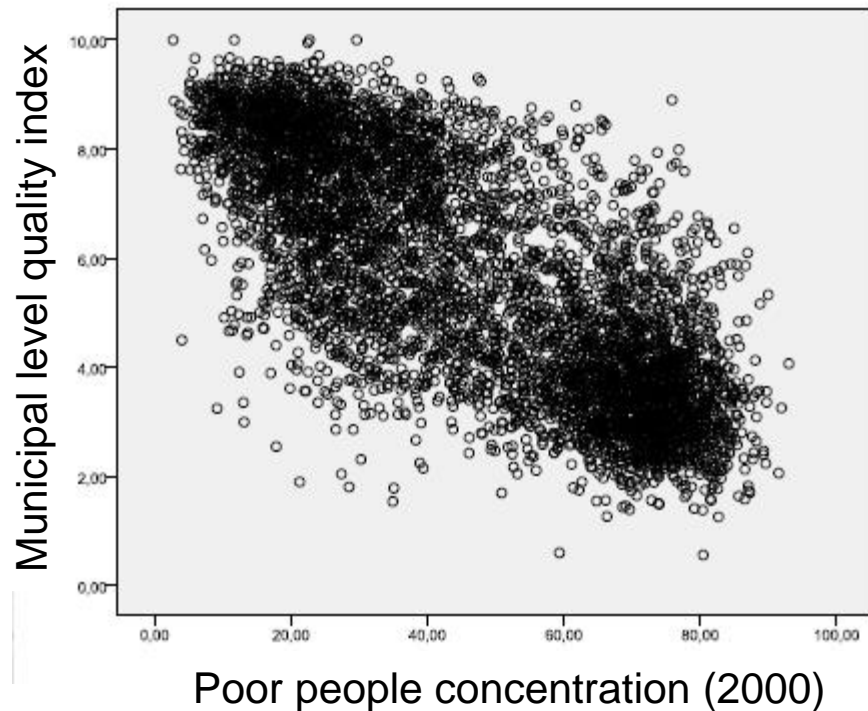

Quality of public health

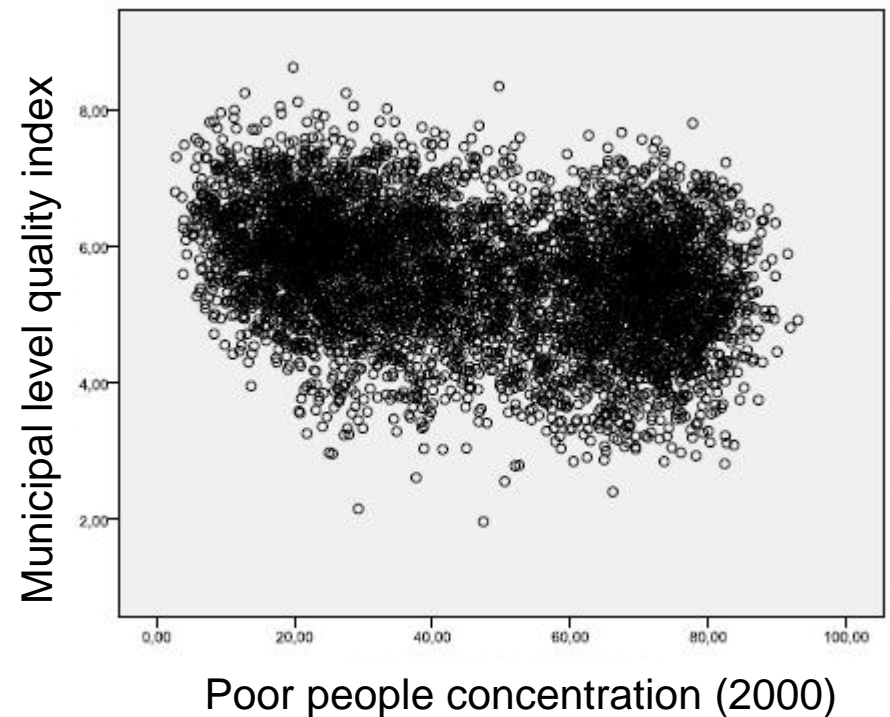

(Source: Marta Arretche (USP and CEBRAP), presentation at FAPESP Week, Oct. 26, 2011)

Brazil: S&T Policy

- 1951: National Research Council, CNPq
 - Fellowships, research grants
- 1951: Coordination for the Qualification of Higher Education Personnel, CAPES
 - Accredit and evaluate graduate courses, offer fellowships
- 1962: São Paulo Research Foundation, FAPESP
 - Fellowships, research grants
- 1967: Research and Projects Funding, FINEP
 - Research grants, infrastructure, business R&D
- 1969: National Science and Technology Fund, FNDCT
 - Federal funds operated by FINEP
- 1934 – 1985: USP, Unicamp, UFMG, UFRJ plus 50+ universities
 - 1960: Full time professorships start in São Paulo (USP)

Innovation environment: Continuing policies

- Industry R&D and innovation (1999), Sectoral Funds (2000), II National S&T&I Conference (2001), Innovation Law submitted to Congress (2002)
- Innovation Law: Law 10.937/2004
 - University-Industry joint R&D
 - Academic Intellectual Property
 - Fostering industrial R&D
 - Tax incentives, procurement, subvention, subsidized loans
- Plus: Industrial and Technology Policy (PITCE, PDP, PACTI)
 - Focal sectors, articulation
- Plus: states initiatives
 - State Foundations, Technology and Science Parks, Universities, Institutes,...

R&D in Brazil

- A strong academic base
 - 15,000 Doctorates granted yearly
 - 40,000 scientific papers published yearly
 - Challenges: impact, reduce geographic concentration in SE, weak international cooperation
- Growing intensity of industry R&D
 - Brazilian companies:
 - Petrobrás: 11st in R&D in Oil Sector
 - Embraer: 17th in R&D in Aerospace
 - Embrapa and state institutes: agrobusiness driver (Brazil 1st in soy productivity, 1st in meat exports, ..)
 - Challenges: too incremental, weak international focus, only 30% of scientists work in industry, weak IP creation

S&T policy

- Business sector innovation
 - State driven through incentives
 - Weak market drivers
- Education and training
 - State driven through investment
 - Access, inclusion, reducing geographic concentration,

The research enterprise in Brazil, 2012

	Researchers	Expenditure (\$ PPP, 2012)
Universities	98,000	12.1 bn
Gov. R&D Institutes	7,000	3.7 bn
Business	41,000	13.4 bn

Research funding agencies

– Federal level

- National Research Council (CNPq)
- Foundation for Higher Education Personnel Training (CAPES)
- Federal Company for Project Funding (FINEP)

– State level

- 25 State Research Foundations

Brasil: R&D expenditures, 2011, by source

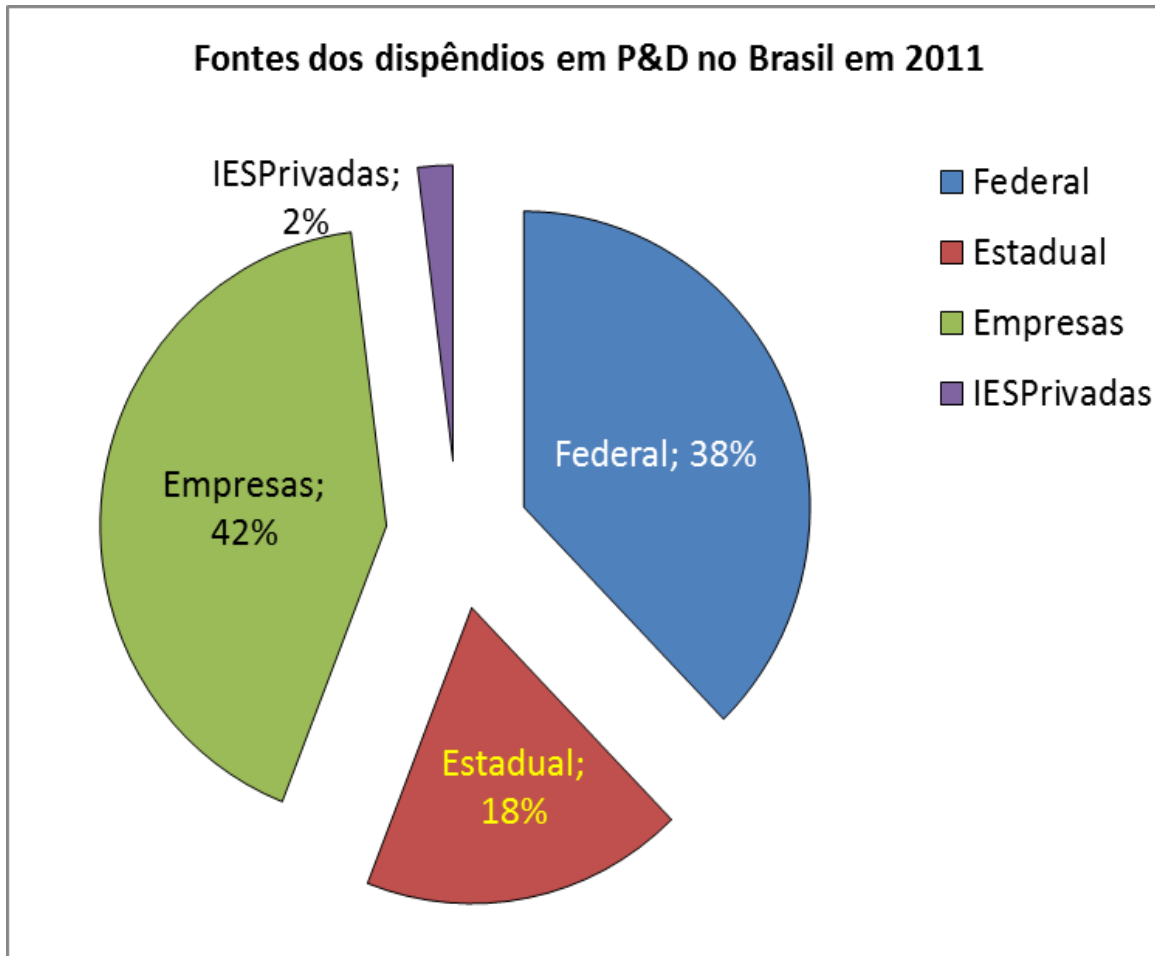

- Intensity – 1.1% GDP
- Public expenditure
 - States 33%
 - Federal 67%

R&D expenditures in higher education institutions, 2012

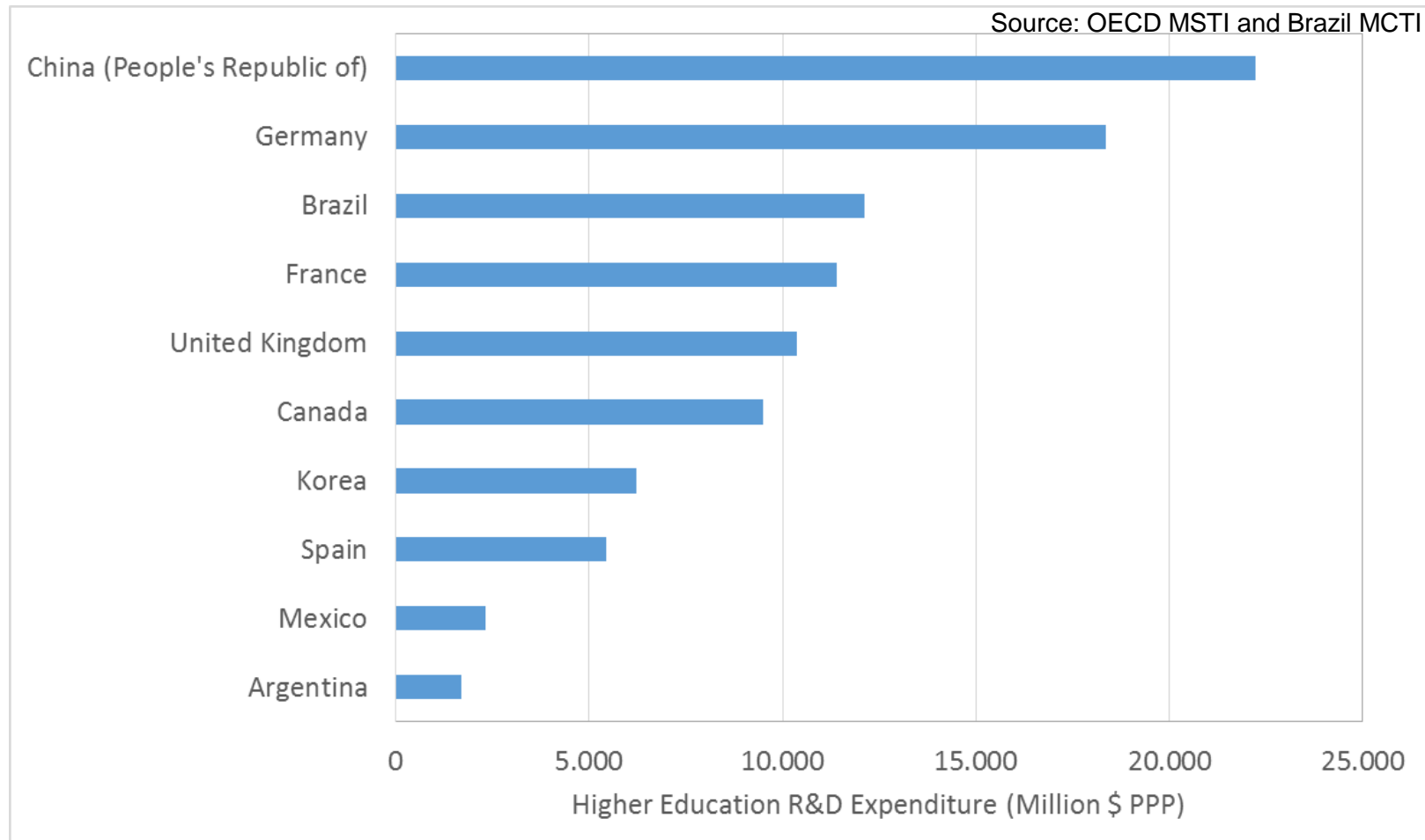

Latin America: scientific articles, 1990-2011

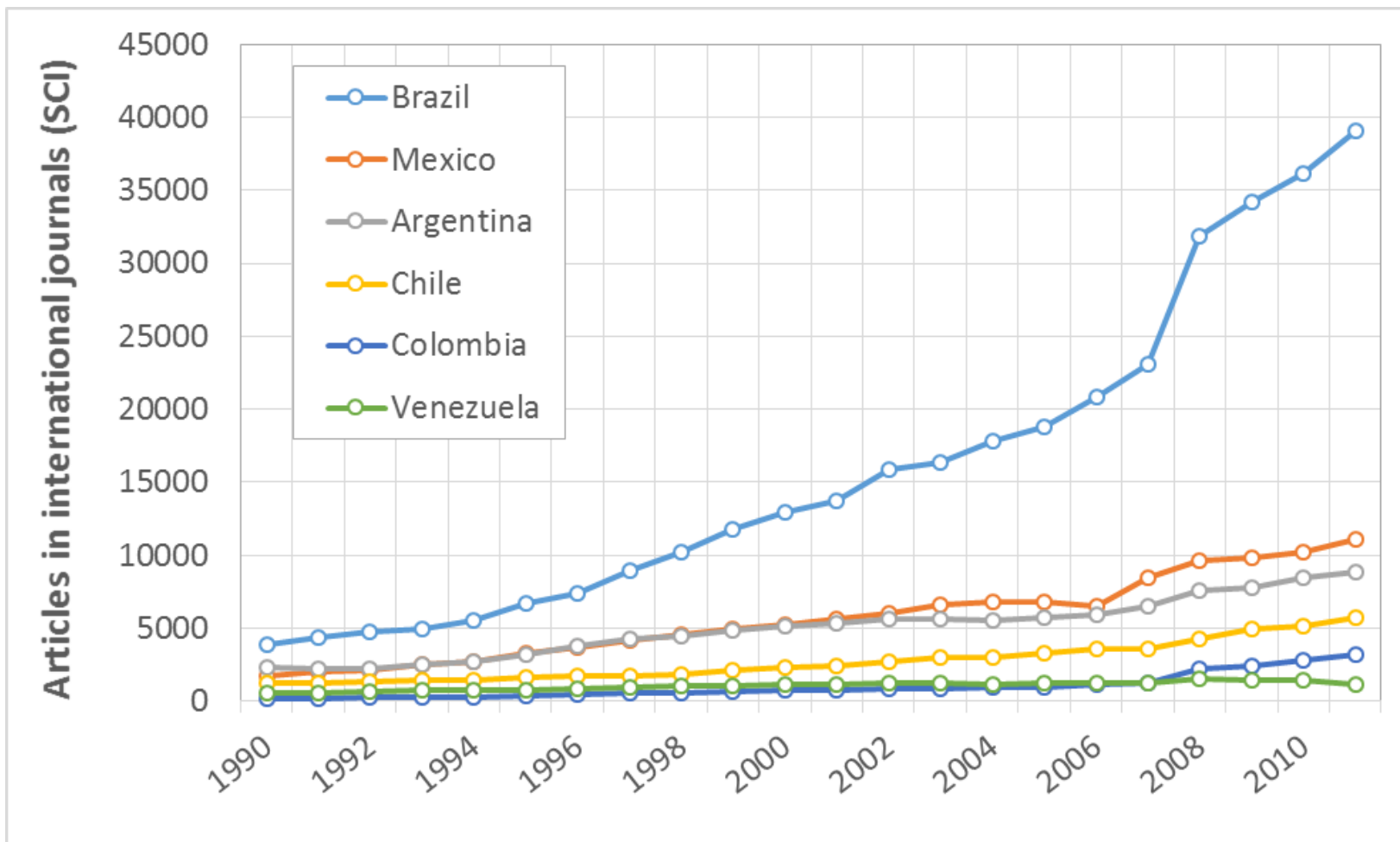

Brazil: some R&D based results

- Energy self sufficiency
 - Bioenergy: more liters of ethanol than liters of gasoline used every year
 - Largest and most efficient Ethanol producer in the world
 - 35% of world Ethanol production
 - > 1 milion flex-fel vehicles, 95% of sales
 - Prospecting, finding and extracting oil at >5,000 ft under the sea
- Best 50 seater jet – Embraer ERJ 145
 - Starting 2006: 90 -110 seat jet ERJ 190
- Food for the world
 - Most productive soybean in the world
 - Largest meat producer

Ethanol and Gasoline use in Brazil

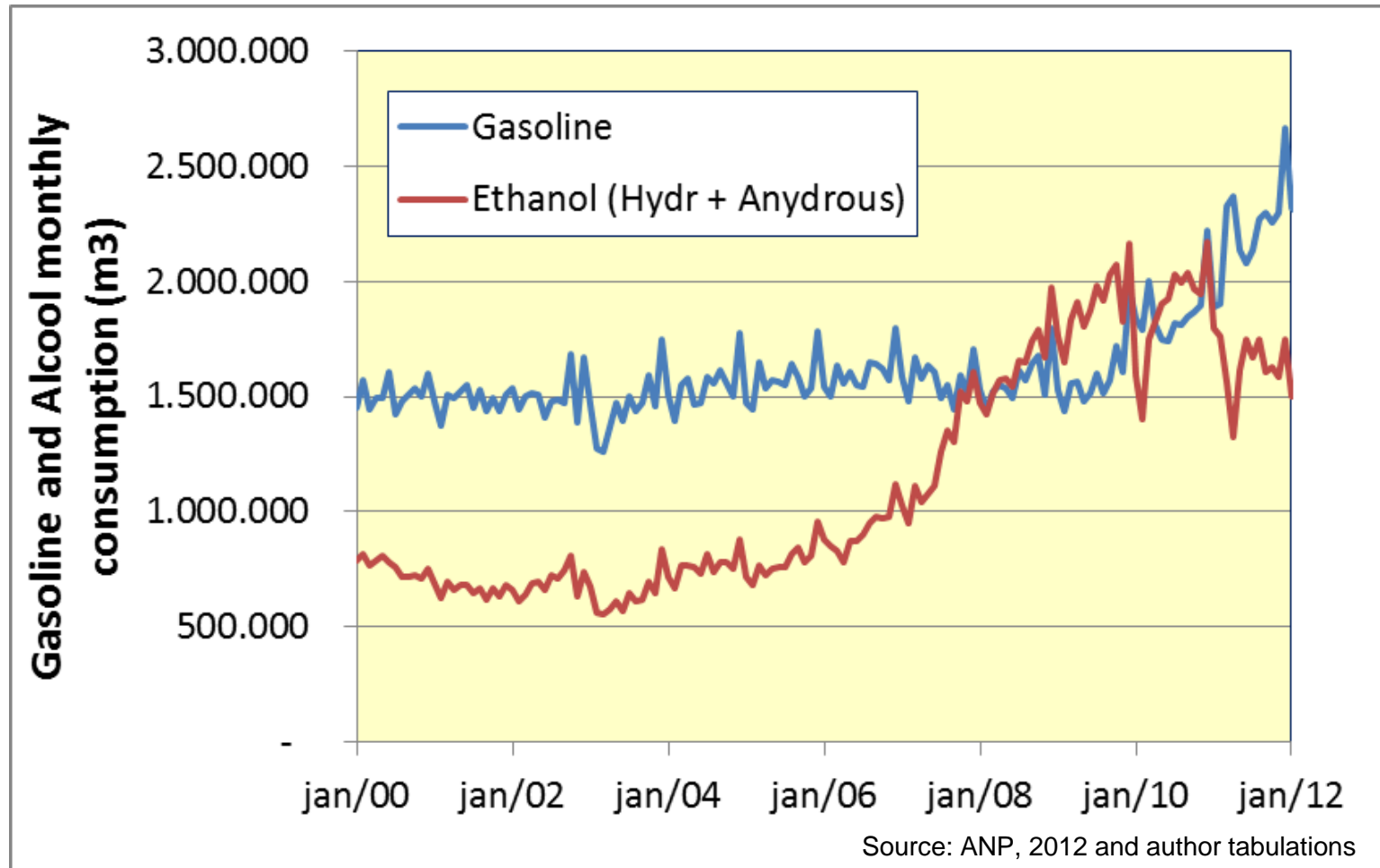

Low business R&D leads to low technology competitiveness (Patents USPTO)

Patents USPTO	2000		2008	
Region/Country	Qty	%	Qty	%
S. Korea	3.314	2.1%	7.549	4.78%
China	110	0.08%	1.225	0.78%
India	131	0.08%	634	0.40%
Iberoamerica	609	0,39%	574	0,36%
Spain	270	0,17%	303	0,19%
Portugal	11	0,01%	11	0,01%
Latin America	328	0,21%	260	0,16%
Brazil	98	0,06%	101	0,06%
Mexico	76	0,05%	54	0,03%
Argentina	54	0,03%	32	0,02%
Venezuela	27	0,02%	14	0,01%
Chile	15	0,01%	13	0,01%
Colombia	8	0,01%	12	0,01%
Cuba	3	0,00%	6	0,00%
Costa Rica	7	0,00%	4	0,00%
Bahamas	13	0,01%	3	0,00%
Uruguay	1	0,00%	2	0,00%

- Smaller share of business patents in 2008 than in 2000
- Unresponsive to S&T policy:
 - Brazil: stagnation after 2001

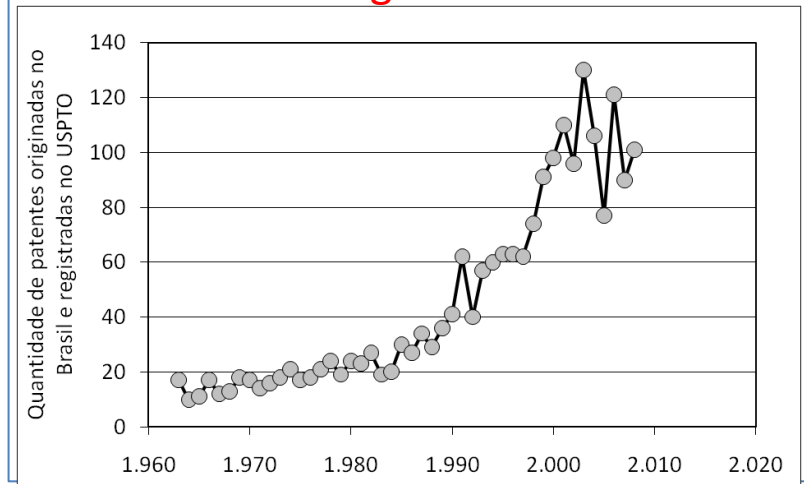

As FAPs no apoio à pesquisa no Brasil

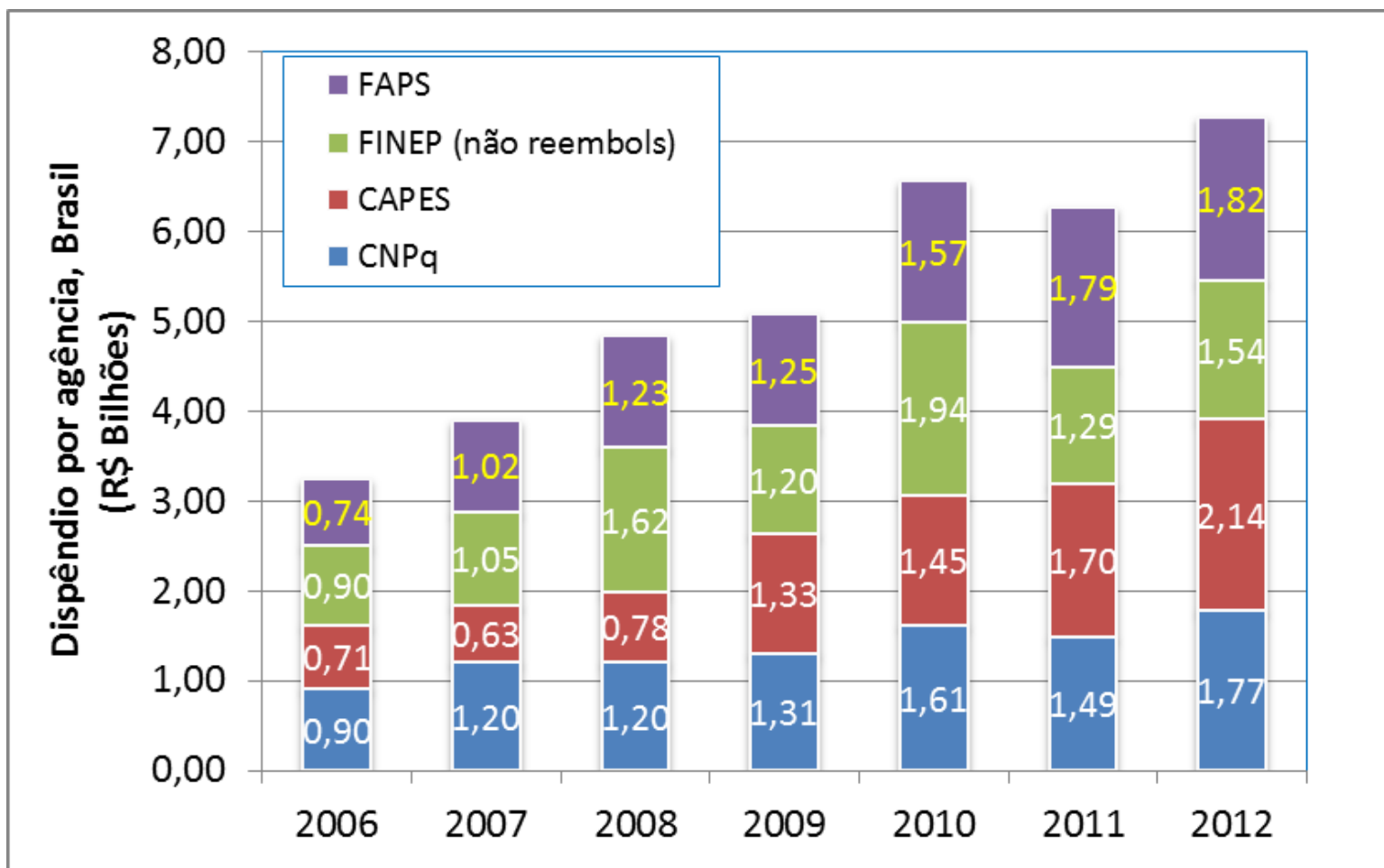

Concentration: 11 universities respond for 74% of the articles

	State	1990	2010
USP	SP	29%	26%
UNICAMP	SP	9%	9%
UFRJ	RJ	8%	7%
UNESP	SP	3%	7%
UFRGS	RS	4%	6%
UNIFESP	SP	4%	5%
UFMG	MG	4%	5%
UFSC	SC	2%	3%
UFSCAR	SP	2%	2%
UFF	RJ	3%	2%
UFPE	PE	2%	2%
Total		70%	74%
Brasil		100%	100%

Science and Technology in Brazil

- A growing scientific base
- 15,000 doctorates graduated yearly
- 40,000 scientific articles per year; 3% of world total
- 600+ research groups in optics and photonics
- Growing connection to industry
- Opportunities for International research collaboration

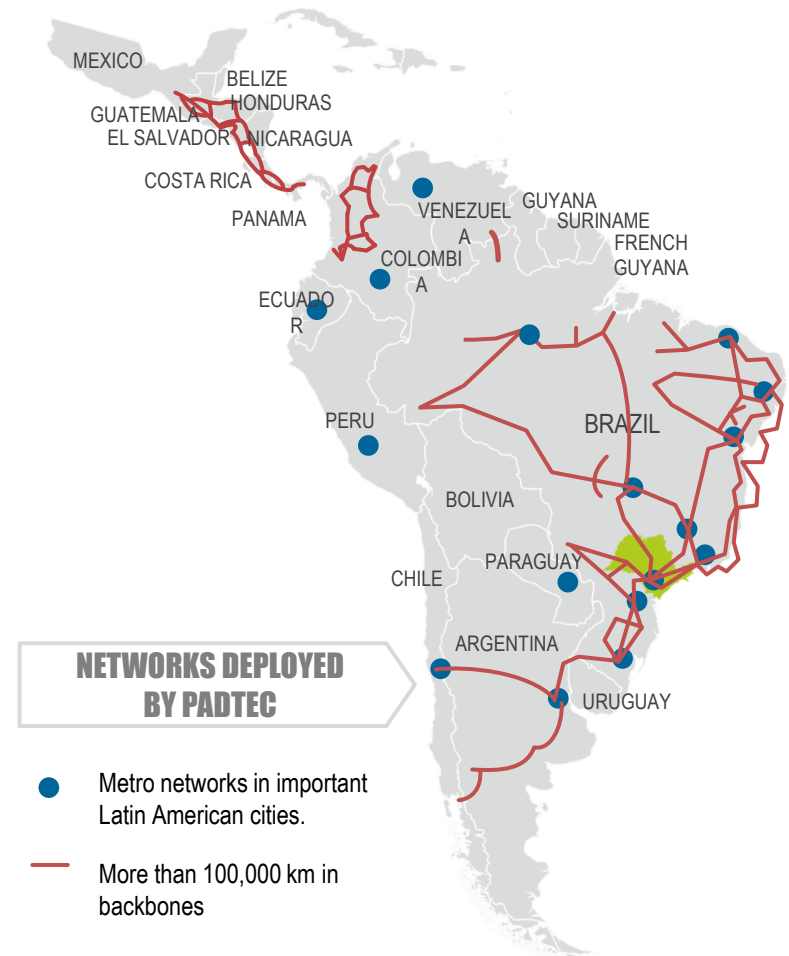



Products

- Optical Backbone
- LightPad i1600G
- Access
- FlexPad
- Standalones
- Download Center

home - products

Products

Optical Backbone



Access



Standalones



Padtec and RNP sign an agreement on technical cooperation during Futurecom

15/10/14 - Padtec signed yesterday (10/1 ...

The state of the art in submarine repeaters is one of Padtec's contributions to Futurecom

13/10/14 - Padtec presents at Futurecom ...

FAPESP: grants and fellowships [ótica or optica or fotonica]

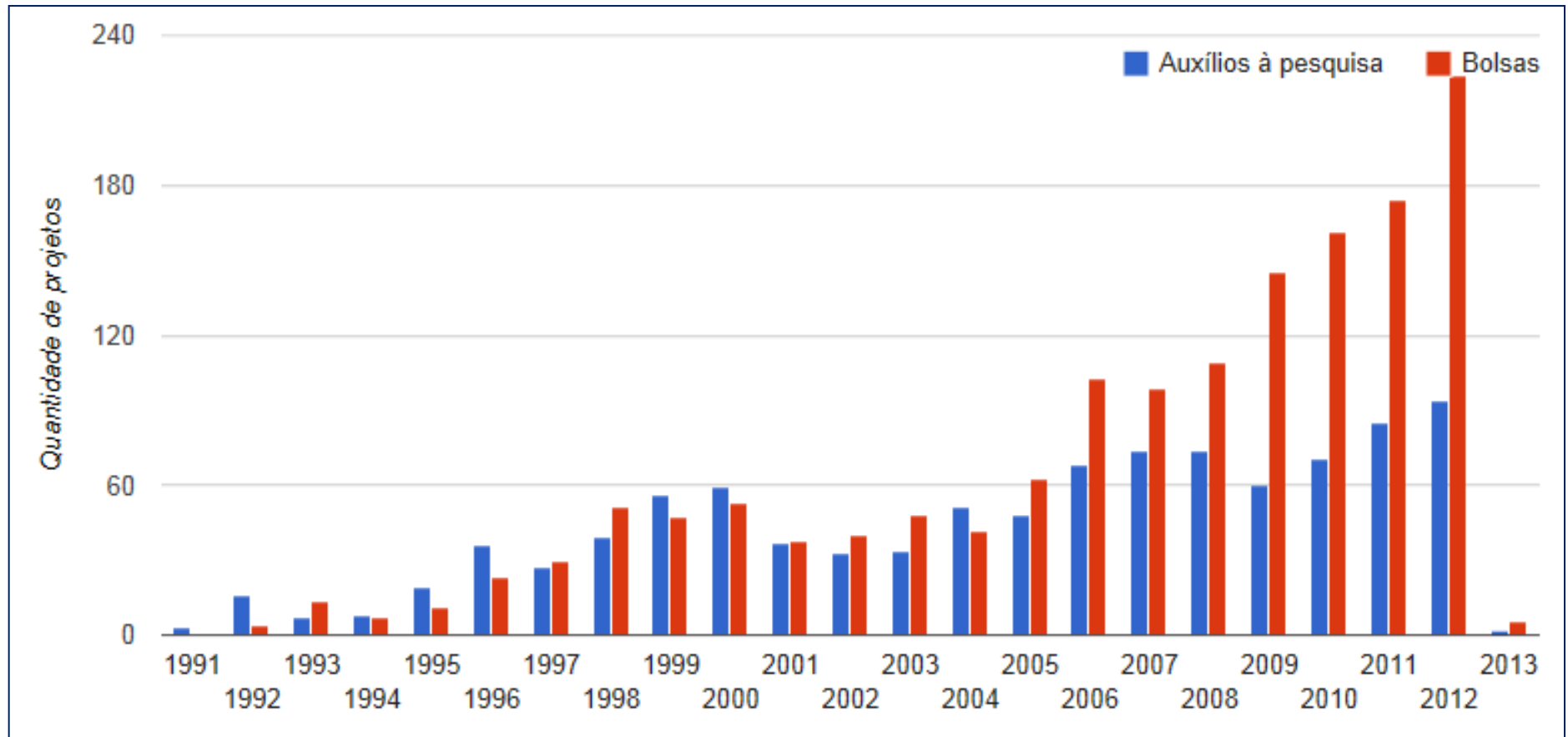

Opportunities for foreign scientists in SP: Young Investigator Awards

- 4 years grant
 - Typical value ranges from US\$ 200 th to US\$ 2 million
 - Fellowship for PI (including travel and installation)
 - Equipments
 - Consummables
 - Travel
 - Fellowships for students
- 5,132 proposals, 1,350 awards since 1996
 - 347p/72a in 2013 (1.5 awards per week)
- Info at <http://www.fapesp.br/en/4479>

Latin America



- 603 million people
 - Brazil 200; Mexico 120; Colombia 47; Argentina 42
 - 63% of Americas' population
 - 35% of the “West”
 - 9% of the world
- GDP US\$ 5.7 trillion (2012)
 - Br 2.9; Mx 1.2; Ar 0.5; Co 0.4
 - 20% of the Americas
 - 11% of the “West”
 - 8% of the world
- GDP per capita
 - US\$ 9,500

Latin America: low Gross Expenditures in R&D as % of GDP, 2012

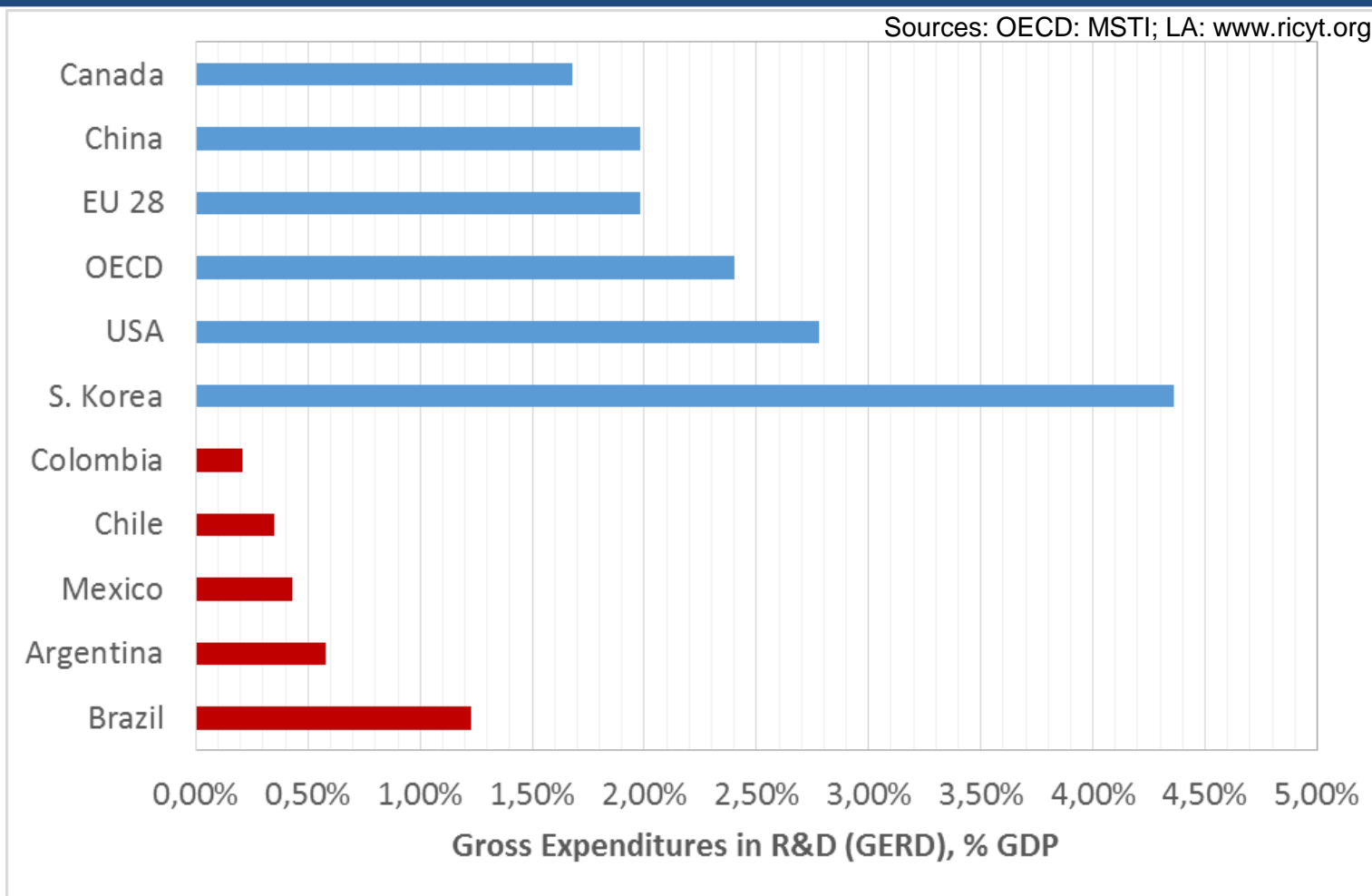

Latin America: low R&D expenditures by business sector, 2012

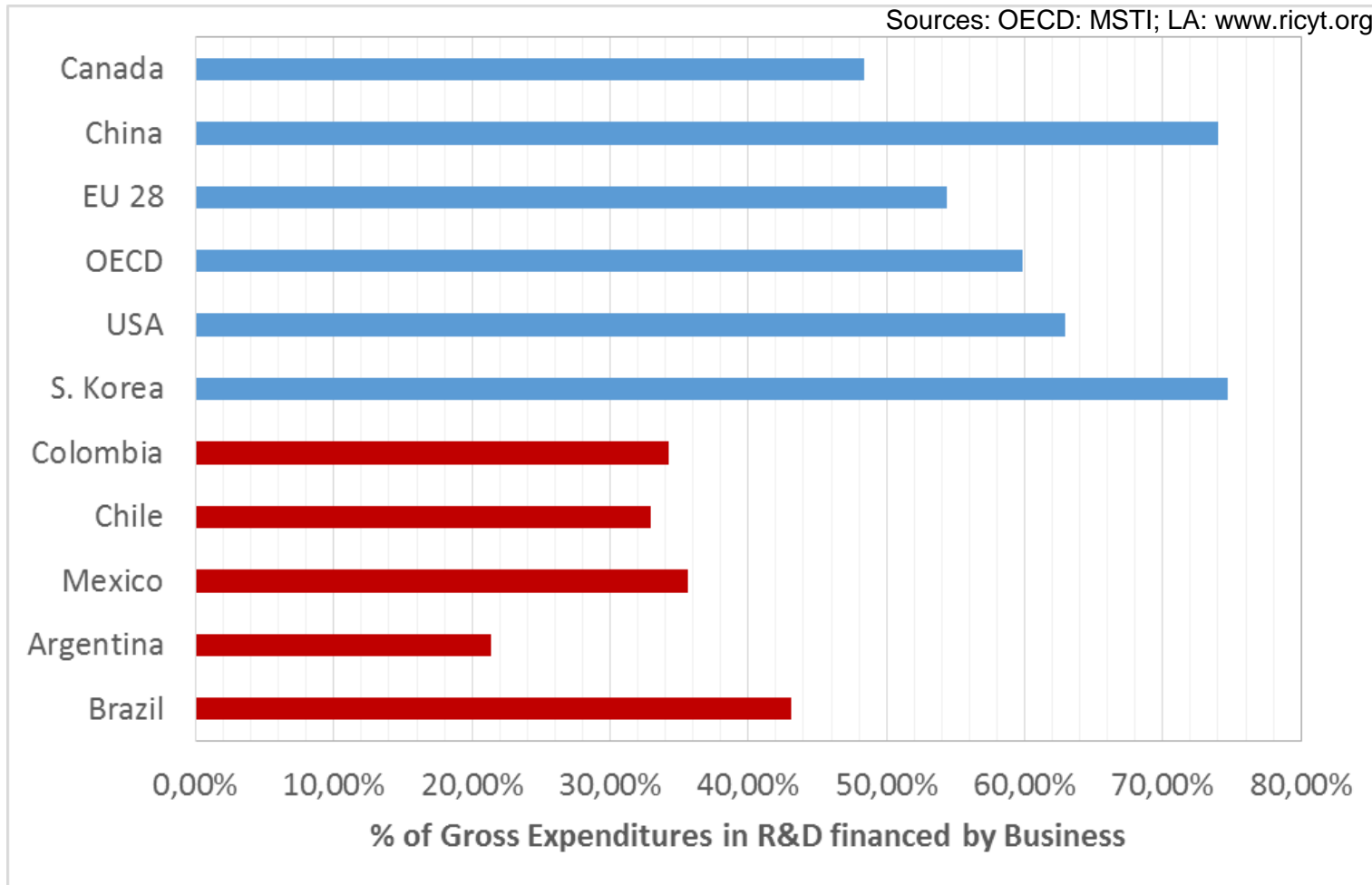

Latin America: doctorates granted, 2012

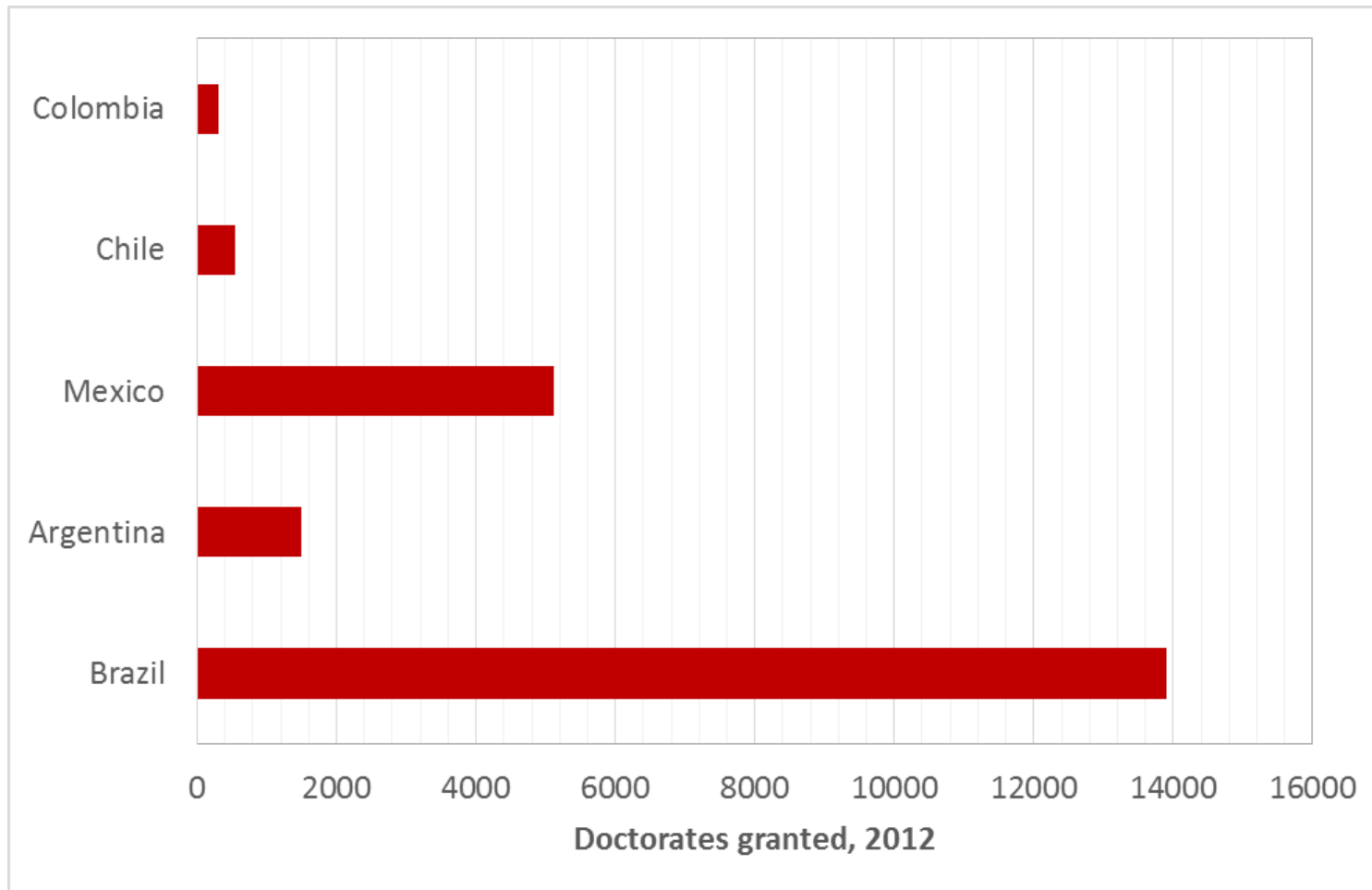

Scientific articles in optics and photonics related fields, main Latin American contributors

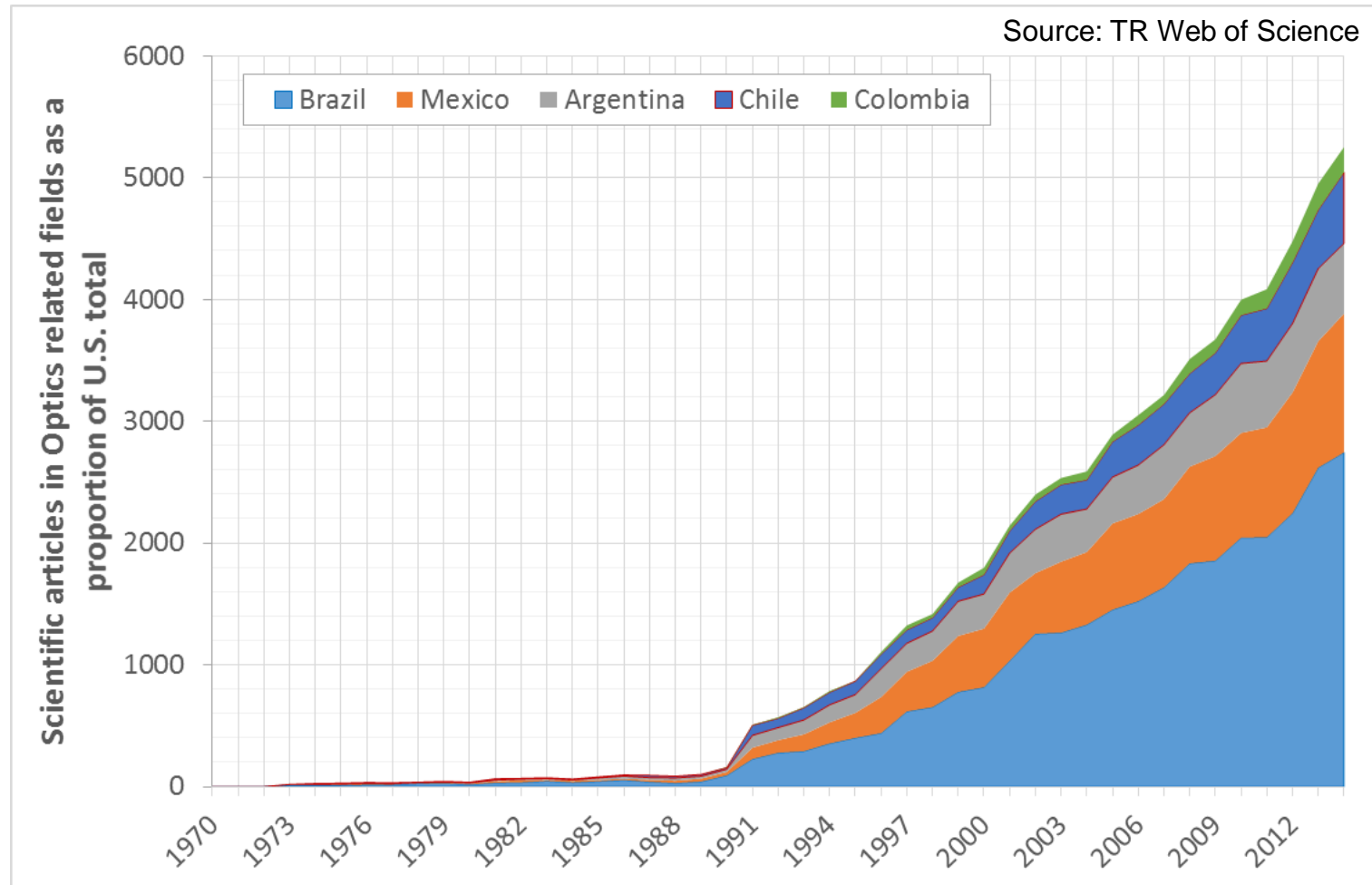

Scientific articles in optics and photonics related fields, as a proportion of U.S. total

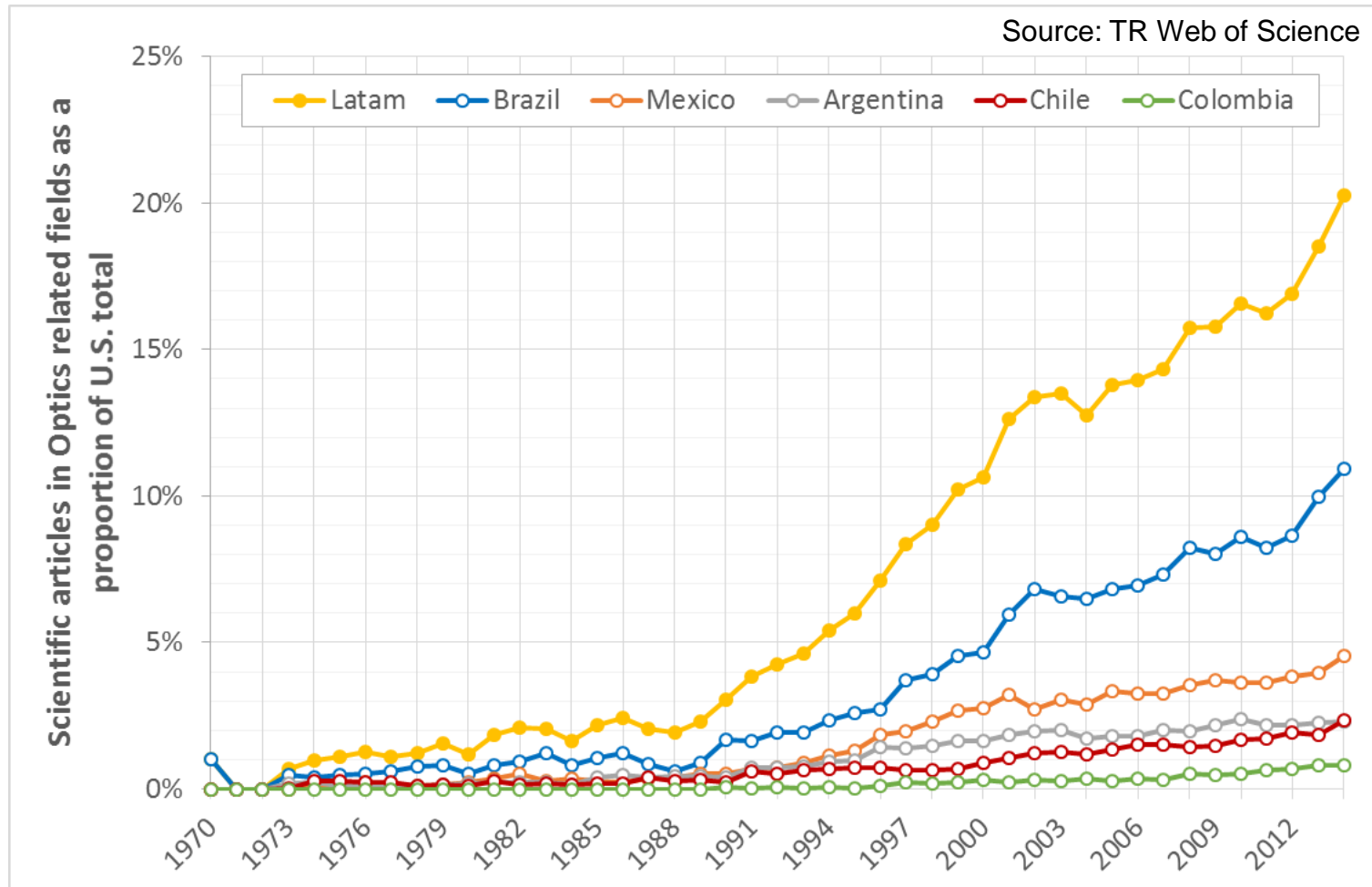

Latin America S&T

- Small, though growing, overall R&D expenditure
 - $\leq 1\%$ GDP
 - Small participation of business in R&D expenditure
- Research happens mostly in universities and institutes
 - Assists in the training of more researchers
 - Hurdles in obtaining more direct economic or social impact